

# **Controller-BRC**

## **User Manual**

Catalog # 100352 Rev.B



Copyright 2002 Intelitek Inc.

Catalog # 100352 Rev.B

January 2002

(Manual v.03 – January 2000)

Every effort has been made to make this book as complete and accurate as possible. However, no warranty of suitability, purpose or fitness is made or implied. Intelitek is not liable or responsible to any person or entity for loss or damage in connection with or stemming from the use of the software, hardware and/or the information contained in this publication.

Intelitek bears no responsibility for errors that may appear in this publication and retains the right to make changes to the software, hardware and manual without prior notice.

**INTELITEK INC.**

444 East Industrial Park Drive

Manchester NH 03109-537

Tel: (603) 625-8600

Fax: (603) 625-2137

<http://www.intelitek.com>

[info@intelitek.com](mailto:info@intelitek.com)

---

# Table Of Contents

<b>1 General Information .....</b>	<b>1</b>
Acceptance Inspection.....	1
Controller Specifications .....	2
Controller General View - Front View .....	4
Controller General View - Back View.....	5
Controller Functions .....	6
Procedures for Aborting Running Robot.....	10
Summary of Panel and Remote Modes .....	11
Inputs/Outputs .....	12
Inputs .....	12
Outputs.....	12
Optional I/O Card.....	13
Inputs .....	13
Outputs.....	13
<b>2 Safety.....</b>	<b>14</b>
<b>3 Installation.....</b>	<b>16</b>
PC-Controller Installation.....	16
Robot-Controller Installation .....	16
Peripheral Devices and Equipment .....	17
Teach Pendant.....	17
Inputs/Outputs.....	17
Peripheral Axes.....	17
<b>4 Maintenance.....</b>	<b>18</b>
Maintenance Procedures .....	18
Opening the Controller .....	18
Replacing the CPU Battery .....	19
Replacing an Internal Fan .....	19
Replacing an External Fan.....	19
Initializing the CPU's memory.....	20
Troubleshooting.....	20
System Messages, Errors and Suggestions for Correcting Them ..22	
<b>Appendix A Simplified Diagrams of BRC .....</b>	<b>41</b>
Main Power.....	41
CPU PC-37000.....	42
CPU .....	43
Axis 1 .....	44
Axis 2.....	45
Axis 3.....	46
Axis 4.....	47
Axis 5.....	48

Axis 6.....	49
Converter.....	50
Front Panel.....	51
I/O PC-37600.....	52
<b>Appendix B Connectors.....</b>	<b>53</b>
I/O Connector - Block I.....	53
I/O Connector - Block II.....	54
Optional I/O Card Connectors - Block III.....	55
Optional I/O Card Connectors - Block IV.....	56
Optional I/O Card Connectors - Block V.....	57
Optional I/O Card Connectors - Block VI.....	58
RS-232 Connectors.....	59
Console Connector.....	59
COM-0 Connector.....	59
Special I/O Connector.....	60
Special I/O Plug Interconnections.....	60
Conveyor Encoder Connector.....	61
<b>Appendix C Interface Circuits.....</b>	<b>62</b>
Sequence Input Circuit Interface.....	62
Output Circuit Interfaces.....	63
Relay type output.....	63
Open-collector transistor type output.....	64
Spare Parts List.....	65



## **WARNING**

- Be sure to turn OFF power before inspection or maintenance. Otherwise, electric shock may result.
- After turning OFF power, wait at least five minutes before servicing the product. Otherwise, residual electric charges may result in electric shock.



## **CAUTION**

- Never use the equipment where it may be exposed to splashes of water, corrosive or flammable gases, or near flammable materials.  
Failure to observe this caution may lead to electric shock or fire.

## **GENERAL PRECAUTIONS**

- Some drawings in this manual are shown as a typical example and may differ from the shipped product.
- This manual may be modified when necessary because of improvement of the product, modification or changes in specifications.  
Such modification is made as a revision by renewing the manual number.



# 1

## General Information

---

### Acceptance Inspection

After removing the Controller from the shipping carton, examine it for signs of shipping damage. If any damage is evident, do not install or operate the Controller. Notify your freight carrier and begin appropriate claims procedures.

Make sure you have received all the items listed on the shipment's packing list. If anything is missing, contact your supplier.

Following are the standard components in the Controller-BRC package.

Standard Controller-BRC Package	
Controller	2 driver cards (for 6 axes); (Optional: driver cards for one additional axis)
Cables	Power Cable RS232 Cable
ACL-Win Software	
Documentation	Controller-BRC User's Manual ACL-Win Reference Guide

The following are optional items for the Controller-BRC.

Optional Items	
Item	Description
Teach Pendant	Supplied with: Mounting fixture, and Teach Pendant User's Manual
Optional I/O Board	Additional 32 input and 32 output

## Controller Specifications

The following table gives the specifications of the Controller-BRC.

Controller-BRC Specifications	
Item	Specification
Case	Free-standing, enclosed frame
Weight	17 kg
Dimensions	289 mm (W) x 433 mm (H) x 317 (D)
Cooling	Indirect
Operating Temperature	0° - 40°C
Relative Humidity	less than 90°; non-condensing
AC Power Input	200 - 230V AC; +10%/-15%; 50 Hz or 60Hz
Grounding	Less than 100 Ohm
Inputs/Outputs	Inputs: 16 opto-isolated 3-5mA Outputs: 4 relay 500mA max, normally-open contact 12 opto-isolated transistors 24V 50mA
Optional Inputs/Outputs Card	Inputs: 32 opto-isolated 3-5mA Outputs: 8 relay 500mA max, normally-open contact 24 opto-isolated transistor 24V 50mA
Motor Driver	AC Servos
Position Feedback Devices	Absolute encoder, 16 bits/turn resolution (Return to Home or Homing not required)
Number of Axes	5 or 6 for robot; additional one (optional)
Acceleration	S-curve profile (smooth acceleration)
User Memory	400 programs; 5000 program lines; 7000 positions (standard configuration)
Programming Language	ACL-Win: Advanced Control Language Full multi-tasking, up to 40 concurrent tasks for robot and cell control Provides wide set of instructions for: <ul style="list-style-type: none"> <li>• Sophisticated trajectory control</li> <li>• Event driven on-the-fly change of trajectory</li> <li>• Torque control</li> <li>• Automatic Programs for: Restart; Emergency; Background Safety</li> </ul>
Program Editing	On-line and off-line by ACL-Win software
Axis Servo Control	Fully digital with absolute encoder and brake control 0.125 $\mu$ position loop



<b>Controller-BRC Specifications</b>	
<b>Item</b>	<b>Specification</b>
	<p>Operation from nominal 300 V DC bus</p> <p>Over-current and short-circuit protection</p> <p>Software detection of thermic overload of motor</p> <p>Emergency stop (limit switches (optional), emergency switch, errors)</p> <p>Error detection: over-current; DC bus over-voltage; DC bus under-voltage; encoder error; DC failure; Watchdog</p> <p>Control parameters in EEPROM of each axis driver</p>
Trajectory Control	<p>Joint, linear and circular interpolation</p> <p>Continuous path with all movement combinations</p> <p>On-the-fly change of speed and acceleration</p> <p>On-the-fly change of trajectory</p> <p>Path reversal</p>
Torque Control	<p>User definable upper and lower torque limits (value and sign)</p> <p>User monitoring of output torque</p>
Cell Control	<p>Emergency connector</p> <p>16 Inputs (12V-24V); 16 Outputs</p> <p>Multi-tasking (independent cell control while robot is working)</p>
Teach Pendant (optional)	<p>Jogging, teaching positions, testing trajectory, running programs</p> <p>25 multifunction keys</p> <p>4 line display</p> <p>Emergency and Dead Man switch</p>

## Controller General View - Front View

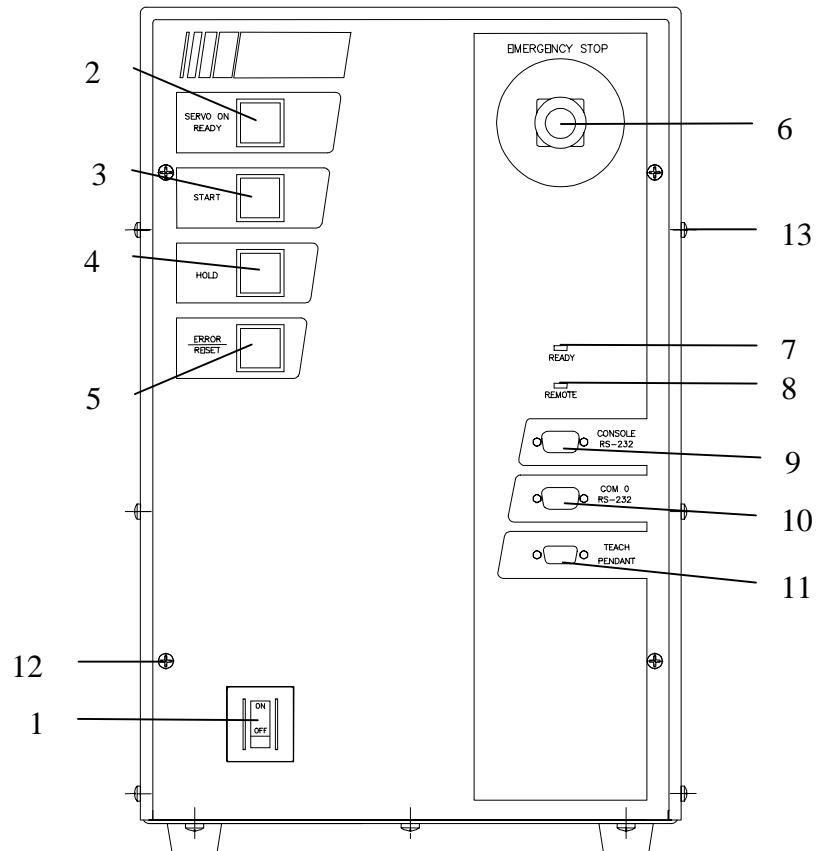

Figure 1-1: Front View

- 1 Power On/Off switch.
- 2 Servo On/Off push button and indicator lamp
- 3 Program Start push button and indicator lamp
- 4 Hold push button and indicator lamp
- 5 Error Reset push button and indicator lamp
- 6 Emergency button
- 7 Ready indicator LED
- 8 Remote indicator LED (lit = Remote)
- 9 Console RS232 port for PC connection to ACL-Win software
- 10 Auxiliary RS232 port (Com0)
- 11 Teach Pendant connector
- 12 Front Panel fastening screws (8 in total)
- 13 Top Cover fastening screws (8 in total)

## Controller General View - Back View

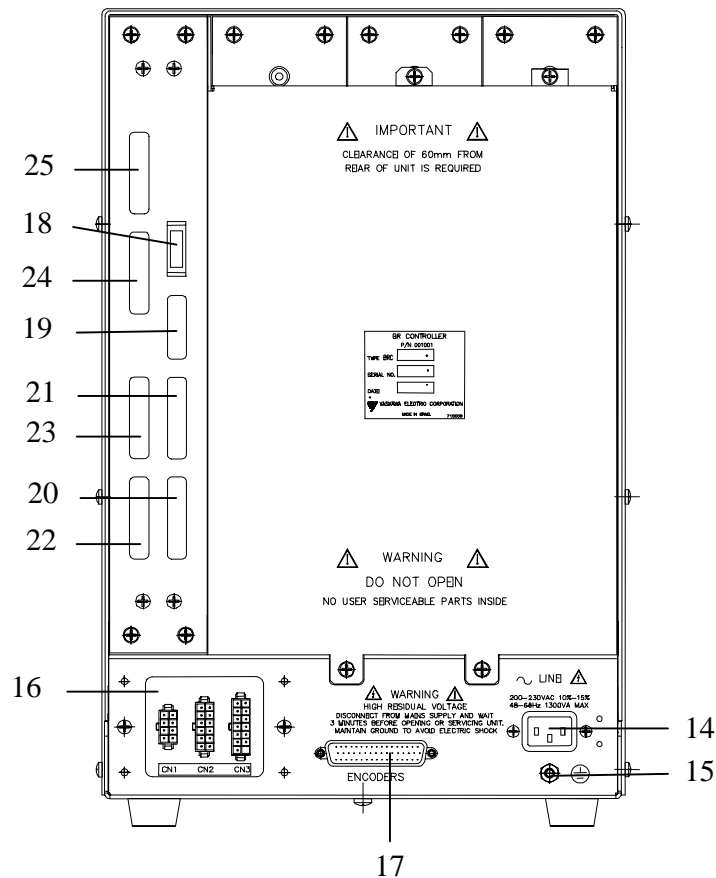

Figure 1-2: Back View

- 14 Power line socket (200-230V AC)
- 15 Ground connection screw
- 16 Robot Motors cable connection cabinet
- 17 Robot encoders cable D50F connector
- 18 Connector for special interface I/Os (for special I/O plug)
- 19 Connector for conveyor interface
- 20 Connector for standard I/O - block I
- 21 Connector for standard I/O - block II
- 22 Connector for standard I/O - block III (optional)
- 23 Connector for standard I/O - block IV (optional)
- 24 Connector for standard I/O - block V (optional)
- 25 Connector for standard I/O - block VI (optional)

---

## Controller Functions

By default, the Controller's front panel switches and lights operate in PANEL mode, i.e. panel switches and lamps are active.

By configuring parameters and issuing the ACL-Win command REMOTE, some panel functions can be operated in REMOTE mode. In REMOTE Mode, control of most of the Controller's front panel functions can be transferred to external switches and signals by means of the system's digital inputs and outputs. The assignment of each function to external I/O is configurable by mean of parameters. (See table 1-3.)

### POWER Switch (1)

This switch turns the Controller on and off.

<b>IMPORTANT</b>
------------------

*After switching off, wait at least 30 seconds before switching on again.*

### SERVO ON/OFF Push Button and Indication Lamp (2)

This button switches ON and OFF the main power supply to the motors.

When the main power supply is ON the indication lamp is lit.

#### Operation in REMOTE mode:

To transfer the function of the SERVO ON switch to an input, set parameter 14 to the input number.

To transfer the function of the indication lamp to an output, set parameter 119 to the output number. (See table 1-3)

### Program START Push Button and Indication Lamp (3)

Pressing this button starts execution of an ACL-Win user program named START, if it exists. If you have not created a START program, pushing this button will have no effect. Once the program is running, pushing this button will have no effect.

The lamp in the START button lights up whenever any program is running.

If the programs are suspended by the HOLD button, press START to restart the program execution from the point of pause.

#### Operation in REMOTE mode:

To transfer the function of the START switch to an input, set parameter 16 to the input number.

To transfer the function of the indication lamp to an output, set parameter 117 to the output number. (See table 1-3.)

## HOLD Push Button and Indication Lamp (4)

When you push this button the Controller enters the HOLD state, and all movement of axes and all running programs are suspended. Push START to resume all suspended programs and movements. Push RESET to abort the program.

When the Controller is in the HOLD state, the HOLD indicator lamp is lit.

**IMPORTANT**

The HOLD switch on the Controller's front panel always remains active, even when REMOTE mode is active. If you press the external HOLD button while in REMOTE mode, the program that you want to stop will be held at the next step, not at the step which is currently being executed. This is because the External HOLD button has normally-closed contacts. A switch with normally-closed contacts gives you the possibility of installing more than one series connected HOLD switches.

### Operating in REMOTE mode:

To transfer the function of the SERVO ON switch to an input, set parameter 15 to the input number.

To transfer the function of the indication lamp to an output, set parameter 118 to the output number. (See table 1-3)

Table 1-1: Conditions of Start and Hold Buttons

STATUS		START		HOLD	
PROGRAM	ROBOT	LAMP	BUTTON	LAMP	BUTTON
RUNNING	RUNNING	ON	DISABLE	OFF	ENABLE
STOP	RUNNING	↑	↑	↑	↑
RUNNING	STOP	↑	↑	↑	↑
STOP	STOP	OFF	ENABLE	OFF	DISABLE
HOLD	HOLD	↑	↑	ON	↑

## **ERROR RESET Push Button and Indication Lamp (5)**

When an error occurs in one of the servo axes and the power to that axis and all axes of the same group are disabled, the lamp in the ERROR RESET button lights up.

In order to re-enable control to all disabled axes, clear the error by pressing the ERROR RESET button.

### **Operating in REMOTE mode:**

To transfer the function of the SERVO ON switch to an input, set parameter 114 to the input number.

To transfer the function of the indication lamp to an output, set parameter 115 to the output number. (See table 1-3.)

## **EMERGENCY Push-button (6)**

Pressing this buttons results in the following:

- Switches off the main power supply of motors.
- Immediately stops all arm movements.
- Disables servo control on all axes.
- Activates all motor brakes.
- Runs program named EMRG, if exists.

This button is self-latching. You must turn the buttons slightly in either direction in order to release it.

## **READY Indication LED (7)**

This LED displays the state of an internal watchdog. Normally this LED remains lit.

If an internal error occurs and the Controller is unable to function properly, this LED will blink.

## **REMOTE Indication LED (8)**

When the Controller is in the Remote Mode, this LED is lit.

To copy the state of the REMOTE LED to an output, set parameter 116 to the output number.

The REMOTE LED will continue to monitor in the REMOTE mode in parallel to the configured output.

### **CONSOLE RS232 Port (9)**

This D9M connector is the communication port for the host PC which is used for programming the Controller.

Use the original cable to connect the Controller to the communication port.

See Appendix B for pinout information.

### **Auxiliary RS232 (COM 0) Port (10)**

This D9M connector provides communication to external devices in the robot cell, such as a vision system, a programmable logic Controller (PLC), barcode reader, and so forth.

See Appendix B for pinout information.

### **TEACH PENDANT Connector (11)**

This D15F high density connector is the communication port for the Teach Pendant (TP).

## Procedures for Aborting Running Robot

Table 1-2: Ways to Stop Running the Robot and Program

ACTION	RESULT			
PRESSED BUTTON	PROGRAMS	SERVO POWER OF MOTORS	BRAKES	MOVEMENT
EMERGENCY ON PANEL	ALL PROGRAMS ABORTED	OFF	CLOSED	OFF
EMERGENCY ON TP				
EMERGENCY EXTERNAL				
SERVO ON READY	STOPS ONLY ROBOT RUNNING PROGRAMS	↑	↑	↑
HOLD	ALL PROGRAMS SUSPENDED	ON	OPEN	↑
ACL -Win STOP	ALL PROGRAMS ABORTED	↑	↑	↑



## Summary of Panel and Remote Modes

Table 1-3: Summary of Panel and Remote Modes

MODE	SERVO ON/OFF		START	
	SWITCH	LAMP	SWITCH	LAMP
PANEL	ENABLE	ENABLE	ENABLE	ENABLE
REMOTE	DISABLE <b>and</b> possible to set parameter 14 to an input number	ENABLE <b>or</b> possible to set parameter 119 to an output number	DISABLE <b>and</b> possible to set parameter 16 to an input number	ENABLE <b>or</b> possible to set parameter 117 to an output number

MODE	HOLD		ERROR RESET	
	SWITCH	LAMP	SWITCH	LAMP
PANEL	ENABLE <b>and</b> possible to set parameter 15 to an input number	ENABLE	ENABLE	ENABLE
REMOTE	ENABLE <b>and</b> possible to set parameter 15 to an input number	ENABLE <b>or</b> possible to set parameter 118 to an output number	DISABLE <b>and</b> possible to set parameter 114 to an input number	ENABLE <b>or</b> possible to set parameter 115 to an output number

---

## Inputs/Outputs

For more information on reading and operating inputs and outputs, refer to ACL-Win Manual.

For pinouts of I/O connectors, refer to Appendix B.

For interfacing I/O circuits, refer to Appendix C.

### Inputs

The Controller-BRC has 16 inputs. The logical state of the inputs is as follows:

	Input ON	Input OFF
Hardware	Voltage applied	Voltage Not applied
ACL-Win	1	0

### Outputs

The Controller- BRC has 16 outputs. The logical state of the outputs is as follows:

		Output ON	Output OFF
Outputs 1-4	Relay N.O. Contact	Closed	Open
Outputs 5-16	Transistor	Conducting	Non-conducting
	ACL-Win	1	0

---

## Optional I/O Card

You have the option to install an additional I/O card with 32 inputs and 32 outputs. The logical states of inputs and outputs are same as in Controller-BRC.

### Inputs

	Input ON	Input OFF
Hardware	Voltage applied	Voltage Not applied
ACL-Win	1	0

### Outputs

		Output ON	Output OFF
Outputs 17-24	Relay N.O. Contact	Closed	Open
Outputs 25-48	Transistor	Conducting	Non-conducting
	ACL-Win	1	0

# 2

## Safety

---

### IMPORTANT



### WARNING



### CAUTION

1. Do not operate the **Controller-BRC** until you have studied this manual thoroughly.
2. Do not install or operate the **Controller-BRC** under any of the following conditions:
  - Where a safety ground connection does not exist.
  - Where the ambient conditions are below or exceed the specified limits.
  - Where subject to high vibrations or shocks.
  - Where exposed to direct sunlight.
  - Where subject to chemical, oil or water splashes.
  - Where corrosive or flammable gas is present.
3. Before you connect the Controller to the BRC power outlet, make sure the outlet supplies 200V - 230V +10%/-15%.
4. To guarantee safety, check the ground connection of the AC Power inlet. (The robot must have a separate wire connected to the ground screw on the Controller; the Controller must have a ground connection.) It is recommended to install an external power stabilising device due to frequent spikes on the power line.
5. You should turn off the Controller's POWER switch:
  - Before you do any work within the working envelope of a connected robot or automated device.
  - Before you connect any inputs or outputs.
6. You should turn off the Controller's POWER switch **and disconnect the power cable from the AC power outlet** before you open or service the Controller.

The power supply units contain dangerously high voltages; the power cable must be disconnected to remove possible shock hazard.

After disconnecting the Controller from the power supply, **wait five minutes** before opening or servicing the unit.
7. It is strongly recommended that additional safety devices, such as mushroom emergency buttons and warning lights, be installed in your system.

*To immediately abort all running programs and stop all axes of motion, do either of the following:*

- Press the Controller's red EMERGENCY button or HOLD button.
- Press the TP's red EMERGENCY button.
- Press the additional EMERGENCY button.

# 3

## Installation

---

**IMPORTANT**

The installation instructions in this chapter refer to the diagrams of the Controller's front and rear panels, shown in Figures 1-1 and 1-2.

---

### PC-Controller Installation

**IMPORTANT**

It is recommended that you connect and check the computer-Controller setup *before* installing the robot or any other hardware.

The fan is on the floor of the Controller, so allow adequate clearance around the Controller, and be sure air passage to the fan is not blocked.



**WARNING**

*Do not connect the Controller to the AC power supply until you are sure that the supply is in the range 200V - 230V +10%/-15%.*

1. Make sure the Controller power switch (1) is turned off.
2. Connect the AC power cable to the Controller (14) and to the AC power supply outlet.
3. Install and configure your computer and monitor according to the manufacturer's instructions. Then turn off the computer's power switch.
4. Connect the RS232 cable (D9 connector) to the CONSOLE port (9) on the Controller and to the RS232 port on the computer. You may use either COM1 or COM2 on the computer.
5. Connect the computer power cable to an AC power source.

---

### Robot-Controller Installation

To connect the robot to the Controller, do the following.

1. Connect the robot ground wire to the Ground connection screw (15).
2. Connect the encoders cable to the D50FrameMaker connector (18).
3. Connect the Motors cable to the Robot motors connection cabinet (16).
4. With 4 flathead M3 screws, fasten the motors cable bracket onto the Controller.

---

## Peripheral Devices and Equipment

*The Controller must be turned off before you connect any devices.*

### Teach Pendant

1. Install the TP Mounting Fixture.

This special fixture is required for reasons of safety.

**IMPORTANT**

*This fixture should be installed outside the working range of the robot, so that operation of the robot with the Teach Pendant inside its fixture will not endanger the operator.*



**WARNING**

The fixture has a magnetic strip which activates a magnetic switch on the TP. When the TP is mounted in this fixture, you can execute programs from the TP; when the TP is hand-held, for safety reasons you cannot activate program execution.

The fixture for mounting the TP is supplied with a set of screws for mounting.

2. Connect the TP to the Teach Pendant D15 connector on the front of the Controller. (Refer to Figure 1-1 #11).
3. Tighten the connector screws.
4. Set the TP Auto/Teach switch to AUTO.

### Inputs/Outputs

The I/O connectors (20 - 25) at the rear of the Controller are to connect external I/O devices .

### Peripheral Axes

To install peripheral devices such as axis 7, contact your agent for instructions.

# 4

## Maintenance

---

---

---

### Maintenance Procedures



#### WARNING

**There is high voltage inside the controller. High residual voltage remains inside the controller for three minutes after you switch it off.**

*Before you open the controller or perform any service procedure, do the following:*

1. Turn off the controller's power switch.
2. Disconnect the power cable from the AC power source.
3. Disconnect all other cables and devices (Encoders cable, Motors cable, Communication cable, Teach Pendant, I/O cables) from the controller.
4. Wait for 3 minutes (due to high residual voltage inside the controller).

*The controller contains electrostatic sensitive CMOS devices. Be sure to observe ESD (electrostatic discharge) regulations for CMOS devices.*

### Opening the Controller

1. Unscrew and remove the 8 screws from the controller's top cover.
2. Remove the cover.
3. Unscrew and remove the 8 flat head screws and the 3 pan head screws from the controller's front panel.
4. Slightly remove the front panel from the controller and twist it to the right.



## Replacing the CPU Battery

The battery is located on the top front corner of CPU card.

Replace only with a Toshiba ER6VC3N or compatible 3.6V lithium battery.

1. Open the controller.
2. The battery is attached to a socket on CPU. Pull out the battery and disconnect the cable from the CPU's J5 connector.
3. Insert new battery into the socket and connect the cable to J5 connector.
4. Close the controller.

## Replacing an Internal Fan

1. Open the controller.
2. Disconnect the cable from connector P6 on Converter card.
3. Unscrew 2 pan head screws on the front of the internal fan and pull the bracket with fan out towards you.
4. Unscrew the 4 flat head screws and replace the fan.
5. Reconnect the bracket with fan and tighten the screws.
6. Reconnect the fan cable to the P6 connector on the Converter card.
7. Close the controller.

## Replacing an External Fan

1. Turn off the controller.
2. Disconnect the power cable from the controller.
3. Unscrew 4 flat head screws on the bottom of controller.
4. Disconnect the cable with a label "EXT FAN" and remove the bracket with fan.
5. Unscrew the 4 flat head screws and replace the fan.
6. Reconnect the cable.
7. Reconnect the bracket with fan and tighten the screws.
8. Close the controller.

## Initializing the CPU's memory

For maintenance procedures or due to an error, it is sometimes necessary to initialize the CPU's memory.

To perform initializing do following:

1. Display the ACL-Win Terminal mode (see ACL-Win Reference Guide).
2. At the command prompt, type:  

```
poke -l 0x780000 0
```

then press Enter.
3. Turn on the Controller twice, in the same way as the first time you switched the Controller on.

---

## Troubleshooting

The following are descriptions of possible controller problems and suggestions for correcting them. Refer also to your robot's User Manual for additional troubleshooting instructions.

### Resetting Power switch

The POWER switch is also a protective circuit breaker. If for some reasons it has been tripped, try to turn it ON again.

Possible causes if problem persists:

- Short-circuit in robot motors cable → replace the cable.
- Short-circuit in converter card → replace the converter.
- Short-circuit in one of two drivers cards → replace the driver.
- Malfunction of power supply units inside the controller → contact Customer Service.

### Controller power does not turn on. "Ready" LED does not light. Fans do not rotate.

- Make sure the AC power supply matches the controller's voltage requirement.
- Make sure AC power is being supplied to the power outlet.
- Make sure the power cable is connected to both the proper power source and the controller.

### Controller power turned on. "Ready" LED does not light. Fans rotate.

- Make sure the "Special I/O" Plug is connected to an appropriate connector at the rear of controller.
- CPU card fatal error.

**No communication between the controller and the computer/terminal. Message appears on the screen:**

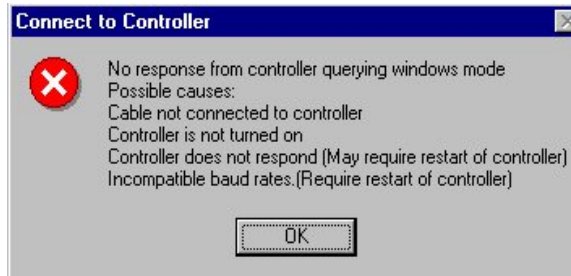

- Make sure the controller's POWER is turned on.
- Make sure the communication cable between the controller CONSOLE port and the computer COM port is properly connected.
- Make sure you have selected the correct COM port in the ACL-Win communications menu settings.

**No communication between the controller and the Teach Pendant.**

- Make sure the controller's POWER is turned on.
- Make sure the teach pendant cable is properly connected to the controller's Teach Pendant port.

*Do not attempt to open the teach pendant. There are no user-serviceable parts inside.*

---

## System Messages, Errors and Suggestions for Correcting Them

This chapter contains a listing of the system messages which may appear on your screen during **ACL-Win** operation and programming. % sign in the messages shown here will be replaced by the number, program name, or variable name when the message is displayed.

When an equivalent message is also displayed on the teach pendant that message [boxed text] is included in the description. Refer to the *Teach Pendant User Manual* for a listing of the teach pendant messages.

The explanations of error messages include instructions for correcting the situation which caused them. System messages which prompt you for a Yes/No response and other self-explanatory messages are not included in this chapter.

**(8) New home position has been set.**

[HOME DONE]

Appears when new home position has been set by user in ACL-Win.

**(46) Driver watchdog error axis %**

[WATCHDOG ERR AX %s]

CPU found watchdog is not correct on driver.

Additional indication: "READY" led blinking 0.5 sec ON and 0.5 sec OFF.

Refer to Diagram 1.

**(72) CONTROL DISABLED.**

[CONTROL DISABLED]

Motors have been disconnected from servo control. Possible causes:

(1) COFF (control off) command was issued.

(2) CON (control on) has not been issued; the motors have not been activated.

(3) A previous errors (such as Impact Protection, Thermic Protection of Trajectory Error) activated COFF, thereby disabling the arm.

If the axes were disabled due to Impact, Thermic, or Trajectory error, check the last movements executed. A movement may have failed because excessive speed or an invalid position resulted in a trajectory beyond the limits of the robot envelope.

**(73) CONTROL ENABLED.**

[CONTROL ENABLED]

Motors are now under servo control and can be activated.

- (85) No available task. Cannot execute program.**  
When in DIRECT mode, the program indicated by the RUN command cannot be executed since the task memory is full.  
  
Probable cause: a program has activated another program many times, without finishing or aborting. Check your program.
- (124) Invalid or undefined axis.**  
The variable used to designate the axis has not been defined, or its index has not been defined, or the axis is not configured (out of range).
- (129) Invalid sequence in program %.**  
Program contains a logic error. For example:  
  
(1) FOR loop not closed by an ENDFOR.  
(2) IF section not closed by an ENDIF.  
(3) ELSE section not closed by an ENDIF.
- (130) Nesting too deep at line n.**  
Nesting is too deep in FOR/ENDFOR or IF/ENDIF routines. A maximum of ten nesting levels is allowed.
- (131) Missing IF for line %.**  
An ENDIF command appears without a preceding IF command.
- (132) Missing IF for line %.**  
An ANDIF or an ORIF command appears without an immediately preceding IF command.
- (133) Missing FOR for line %.**  
An ENDFOR command appears without a preceding FOR command.
- (134) Missing WHILE for line %**  
An ENDWHILE command appears without a preceding WHILE command.
- (142) Missing LABEL for GOTO at line %.**  
A GOTO command appears without a corresponding LABEL in the same program.
- (148) To perform action - release emergency button.**  
[EMERGENCY]  
The emergency button has been pressed.  
  
To resume normal operation: release the emergency button, then activate CON.  
Refer to Diagram 2.
- (153) Cannot execute command. TP must be in Auto mode.**  
This command can only be executed when the TP is in Auto mode.

**(155) Cannot execute command, not in Auto mode.**

You have switched the TP from TEACH to AUTO position, but have not yet clicked OK button in the prompt:



As soon as you click OK the command can be executed.

**(166) Invalid Axis**

You attempted to use an invalid axis number in a CON, BRAKE, or other command.

**(169) Axis enabled, brake already released or driver error  
[BRAKE RELEASE ERROR]**

Occurs during maintenance work on the controller if CON command is given after brakes have already been released. Execute COFF and then execute CON again.

**(174) Invalid robot position array %**

**(175) Invalid variable array %**

**(176) Invalid axis7 position array %**

(174), (175) and (176) messages appears when the controller is undergoing maintenance in Terminal (DOS) mode.

In all instances, clear the CPU's memory. For instructions on how to clear the CPU's memory refer to the Maintenance Chapter .

**(177) Task doesn't exist**

Appears in ACL-Win when you attempt to press the STOP button for a program that is not running.

**(179) ROM Error**

[ROM error]

Fatal error in the Read Only Memory - contact your agent.

**(180) Converter's temperature is too high**

[Converter too hot]

Hardware detected an overheating of the converter's heatsink. Possible causes:

(1) Fans inside the controller not functioning.

(2) Not enough space for air circulation around the controller.

**(181) RAM error**

[RAM error]

Fatal error in the Random Access Memory - contact your agent.

**(183) DC 24 volt failed**

[DC 24V FAIL]

+24V fail detected on CPU. In such instances, the following occurs:

- (1) All arm movements stop immediately.
- (2) Servo control is disabled on all axes.
- (3) All motor brakes are activated.

Contact customer service.

**(184) DC 5 volt failed**

[DC 5V FAIL]

Same as 183: DC 24 V failure. Contact customer service.

**(201) SERVO switch is OFF.**

[SERVO SWITCH IS OFF]

The command could not be executed because the controller's Servo switch is off.

Be sure the Servo switch is turned on. Then repeat the command. Refer to Diagram 3.

**(205) PROGRAMS ABORTED.**

[ALL PROGRAMS ABORTED]

Possible cases:

- (1) The command A was entered from the keyboard.
- (2) The Abort key on the teach pendant was pressed.
- (3) The hand-held teach pendant was switched from Auto to Teach mode during program execution.
- (4) The mounted teach pendant, in Teach mode, was removed from the fixture during program execution.

**(212) Error must be reset.**

[SERVO ERROR]

An error previously occurred and was not cleared. Check the cause and clear it, then press ERROR RESET button.

**(218) Over Voltage axis %.**

[OVER VOLT AXIS %s]

The driver of the specified axis detected excessive voltage and disabled the axis.

Possible causes:

- (1) The AC input power was higher than the maximum voltage allowed.
- (2) An accessory motor has caused excessive power regeneration.

Refer to Diagram 4.

**(219) Thermic Overload axis %.**

[THERM OVRLOAD AX %s]

Software has detected excessive average RMS current inside motor. Possible causes:

- (1) Movement too fast or payload too heavy.
- (2) Too many consecutive high speed movements. Although ACL allows fast movements, and takes advantage of the peak current allowed in motors, this peak current cannot be used continuously. The software constantly checks the true RMS power dissipated in the motors and protects them from burning out.
- (3) The arm attempted to reach a position, which could not be reached due to an obstacle (for example, a position defined as being above a table, but actually slightly below the table's surface). The impact protection is not activated because the obstacle is close to the target position. However, integral feedback will increase the motor current and the motor will overheat, subsequently causing the thermic protection to be activated.

Check the positions and parameters. Reenable servo control of the motors: "CON". Refer to Diagram 5.

**(220) Over Current axis %.**

[OVER CURRENT AXIS %s]

The hardware has detected excessive current in the motor for the specified axis.

Possible cause: A short-circuit in the motor wires or in the motor itself.

Refer to Diagram 6.

**(221) Encoder Error axis %.**

[ENCODER ERR AX %s]

An incorrect encoder connection has been detected.

Check the encoder connections.

Refer to Diagram 7.



**(222) Clockwise Limit axis %.**

(optional-in case of robot with limits)

[CLKWISE LIMIT AX %s]

The specified axis has reached its clockwise limit, and the system aborted the movement. Use the TP or keyboard to send the robot back into its working envelope.

**(223) Counter-Clockwise Limit axis %**

(optional-in case of robot with limits)

[CCLKWISE LIMIT AXIS %s]

The specified axis has reached its counter-clockwise limit, and the system aborted the movement. Use the TP or keyboard to send the robot back into its working envelope.

**(225) Under Voltage at axis %.**

[UNDER VOLTAGE AXIS %s]

The driver of the specified axis detected low bus voltage and disabled the axis. Refer to Diagram 8.

**(227) DPRAM watchdog error at axis %.**

[DPRAM WTCHDG AX %s]

Refer to Diagram 1.

**(229) Driver not responding at axis %.**

[DR NOT RESPOND AX %s]

A problem has occurred on the driver card for the specified axis.

Additional indication: READY LED 0.5 sec ON and two fast blinks.

Possible causes:

- (1) Software on CPU has detected communication watchdog with axis.
- (2) Drivers and VIF can't see the software watchdog of CPU.
- (3) CPU sends illegal code.

Refer to Diagram 1.

**(262) !!! HOLD !!!**

[!!! HOLD !!!]

The controller's Hold switch has been pressed to Hold, thereby suspending axis movement and all running programs.

**(263) !! CONTINUE !!**

[!! CONTINUE !!]

The controller's Start button has been pressed while in HOLD mode, thereby resuming suspended movements and programs.

- (268) **Axis % had out of range parameters**  
[AX %s OUT OF RANGE PAR]  
Wrong values were assigned to driver parameters.  
Check and adjust parameters (refer to the ACL-Win Reference Guide).
- (269) **External fan failure**  
[EXTERNAL FAN FAIL]  
CPU has detected the external fan failure. Refer to the Maintenance instructions.
- (270) **Internal fan failure**  
[INTERNAL FAN FAIL]  
CPU has detected the internal fan failure. Refer to the Maintenance instructions.
- (271) **Warning: Encoder low battery axis %**  
[ENC LOW BATTERY AX %s]  
Encoder has detected low lithium battery voltage inside the robot. Refer to Diagram 9.
- (272) **Warning: Servo Power Off**  
[SERVO POWER OFF]  
Appears when servo power is switched off while “Control On” is enabled. In such instances, the program RECOV (but not program AUTO) will start after controller power is restored (provided the programs are present in memory).
- (286) **Error: program is being debugged through TP**  
Appears when you attempt to press the SUSPEND button for a program that is not running.
- (287) **Warning: CPU low battery**  
[CPU LOW BATTERY]  
CPU detected low lithium battery voltage. You should replace the battery. Refer to the Maintenance instructions.
- (306) **Invalid program.**  
[BAD PRG %s]  
The RUN, GOSUB, TRIGGER command cannot be executed, due to faulty syntax or logic in the program.
- (308) **Driver voltage failure axes %%%**  
[DRIVER DC FAIL %s]  
Driver has detected +5V voltage out of normal range. Check voltage and replace the SGDC card if necessary. If problem reoccurs change driver card.  
Refer to Diagram 10.

**(316) No gripper configuration.**

[NO GRIPPER]

You attempted to use a command that indicates the presence of a gripper. The command cannot be executed because a gripper has not been configured.

**(324) Communication error with driver**

[DRIVER COMM ERROR]

Possible causes:

- (1) Communication error CPU with driver.
- (2) Illegal command or checksum error of driver software.

Refer to Diagram 11.

**(325) Too large speed**

[TOO LARGE SPEED]

Alarm occurs due to a wrong working environment.

Possible causes:

- (1) Wrong points, speed, working area in program.
- (2) User tries to execute "CON" command while one axis is moving.

The dynamic brake used on the axes creates a short circuit on motor winding to activate a braking regeneration. This dynamic brake is activated if a movement is detected while servo power is disabled. The dynamic brake should not be activated when executing a "CON" command. For this, ensure that a movement or vibration is not forced on the robot axis by an external device.

# Diagram 1

ERROR (46) DRIVER WATCHDOG ERROR AXIS %  
ERROR (227) DPRAM WATCHDOG ERROR AT AXIS %  
ERROR (229) DRIVER NOT RESPONDING

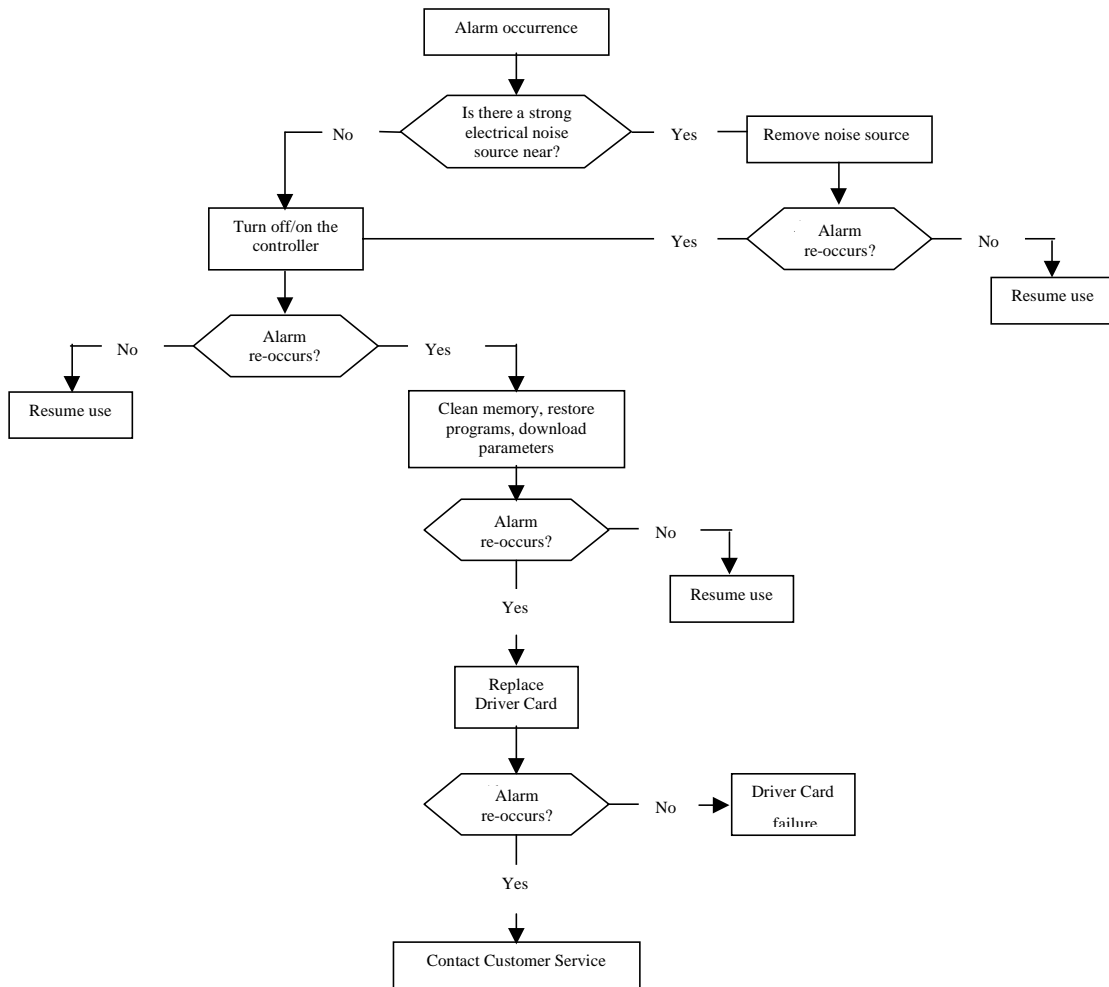

## Diagram 2

### ERROR (148) TO PERFORM % RELEASE EMERGENCY BUTTON

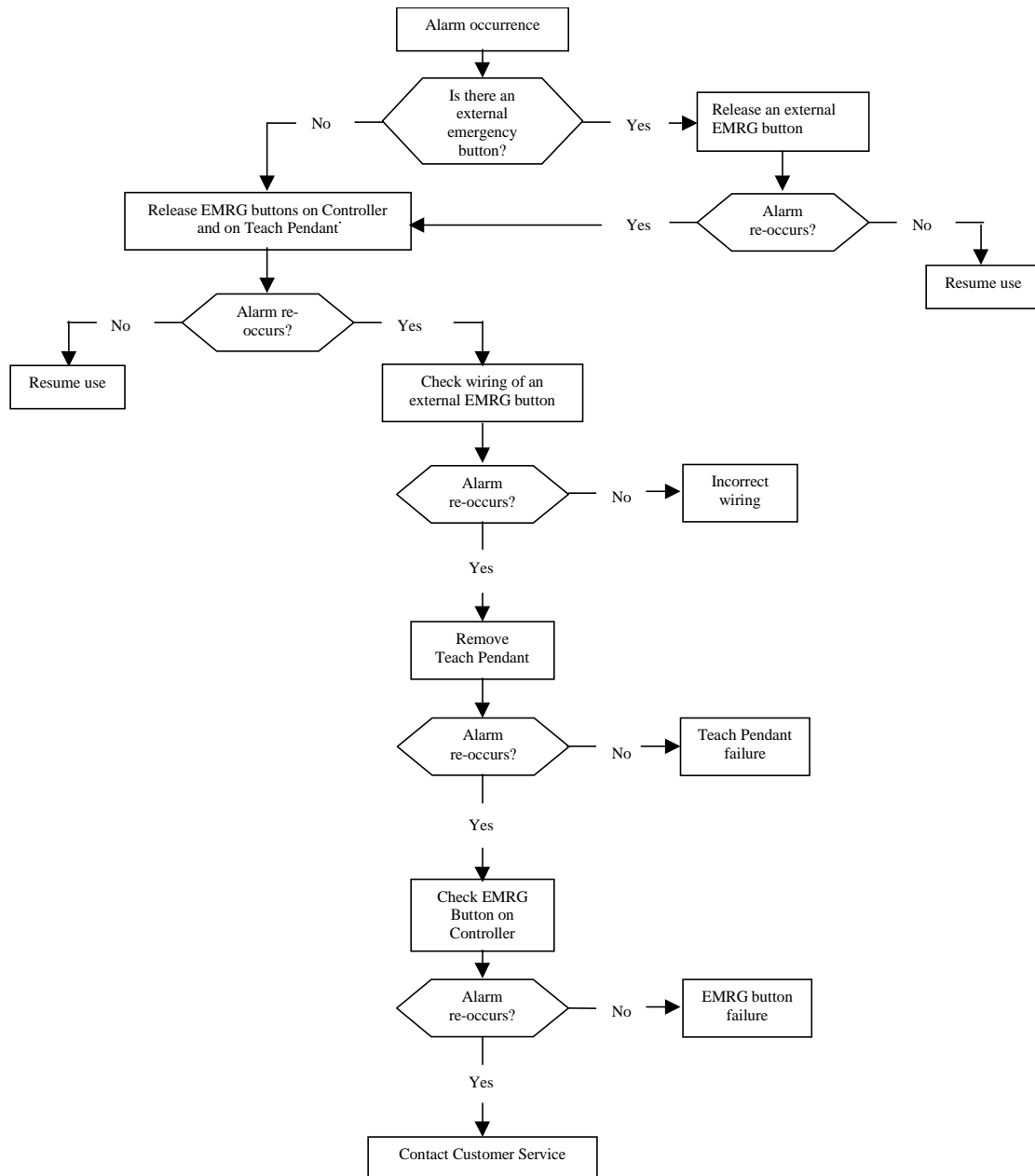

### Diagram 3

#### ERROR (201) SERVO SWITCH IS OFF

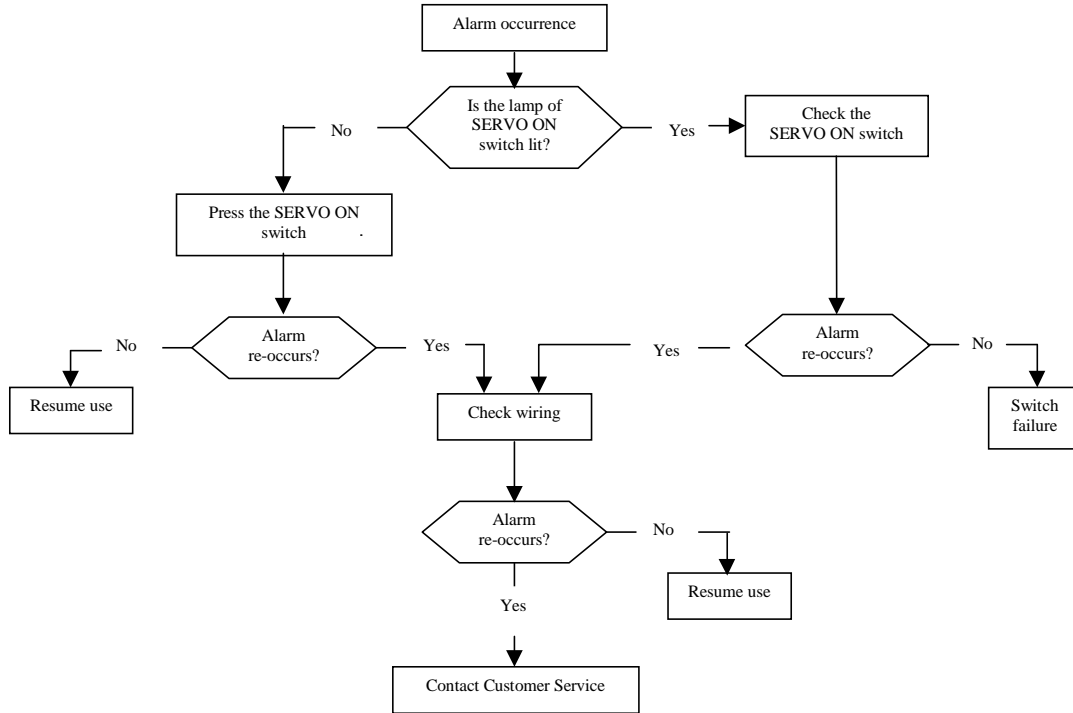

## Diagram 4

### ERROR (218) OVER VOLTAGE AXIS %

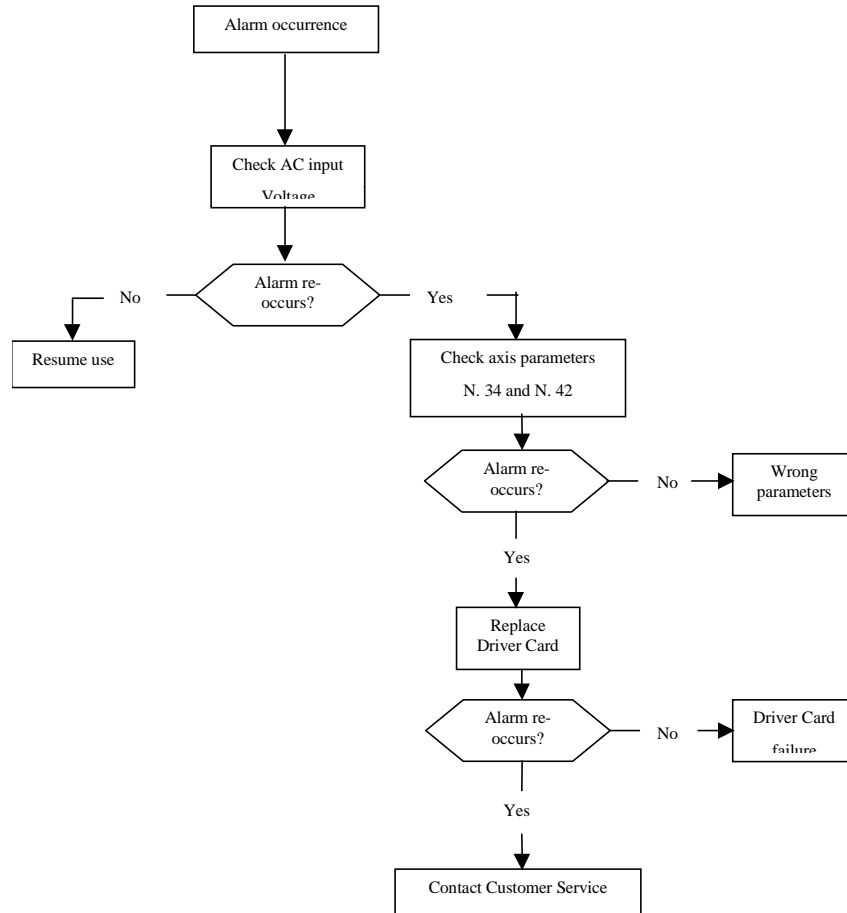

## Diagram 5

### ERROR (219) THERMIC OVERLOAD AXIS %

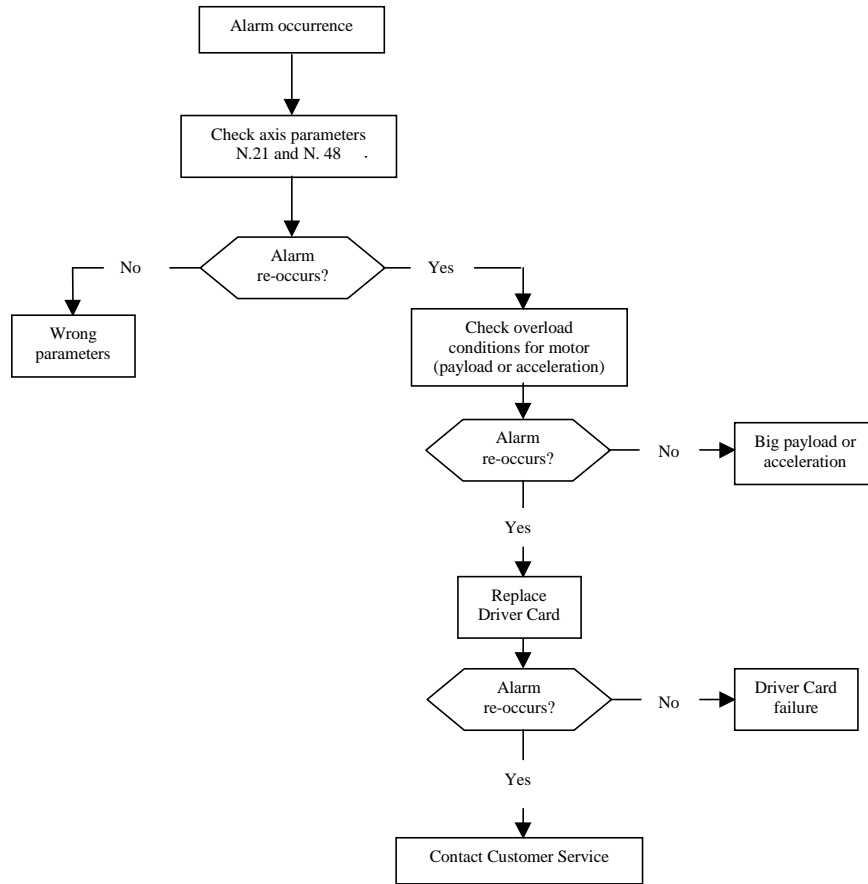



## Diagram 6

### ERROR (220) OVER CURRENT AXIS %

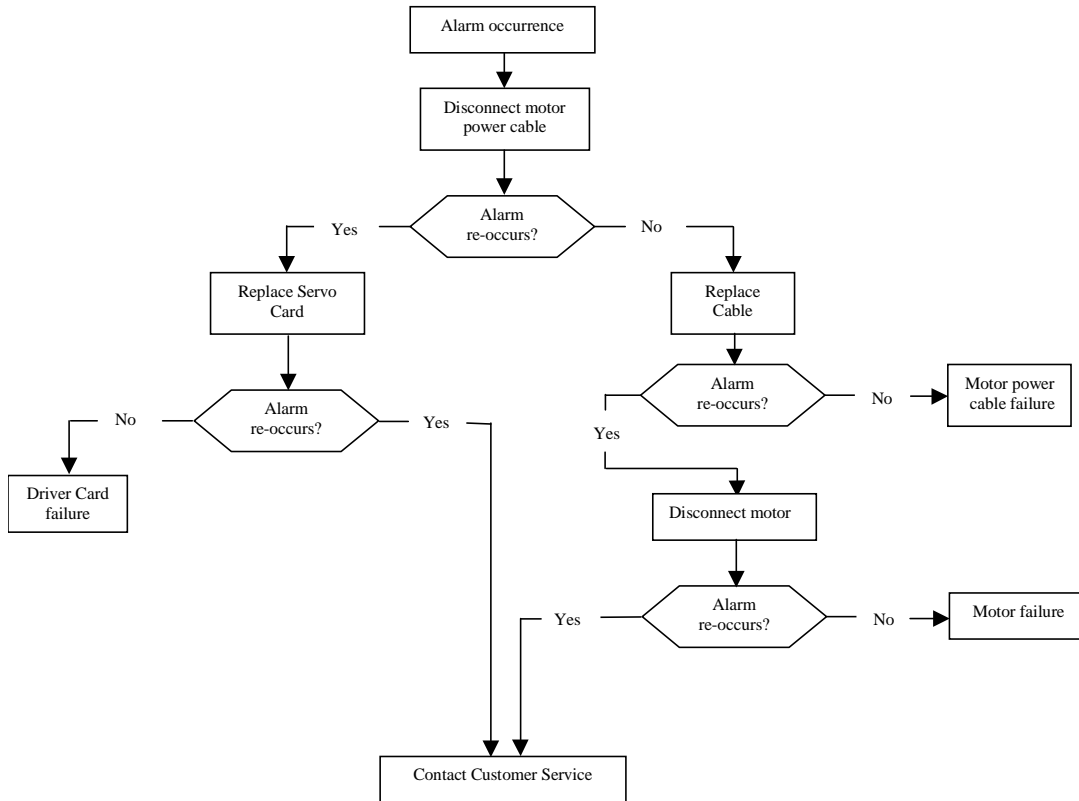

## Diagram 7

### ERROR (221) ENCODER ERROR AXIS %

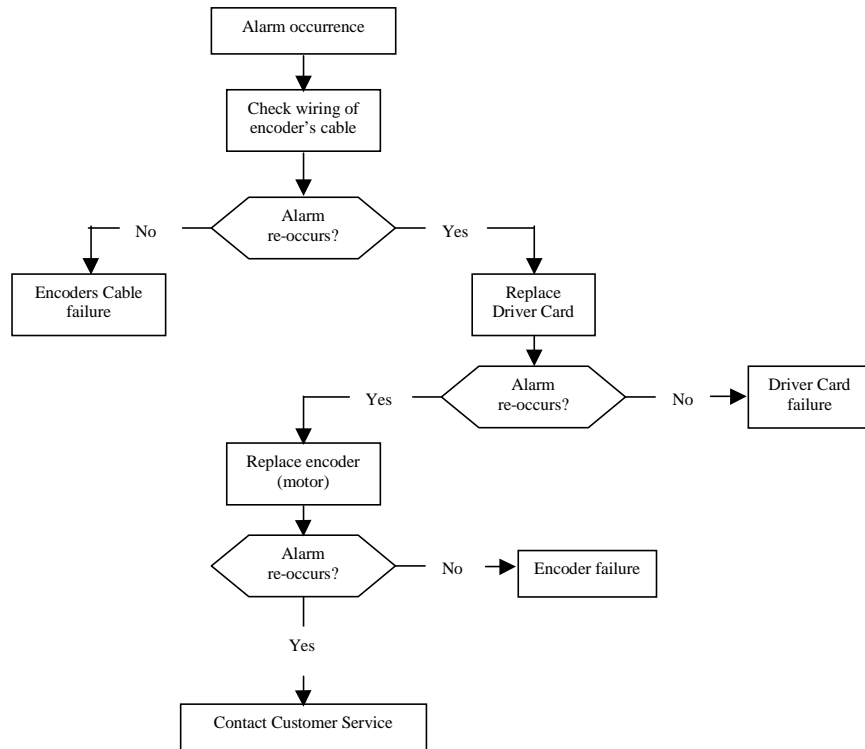

## Diagram 8

### ERROR (225) UNDER VOLTAGE AXIS %

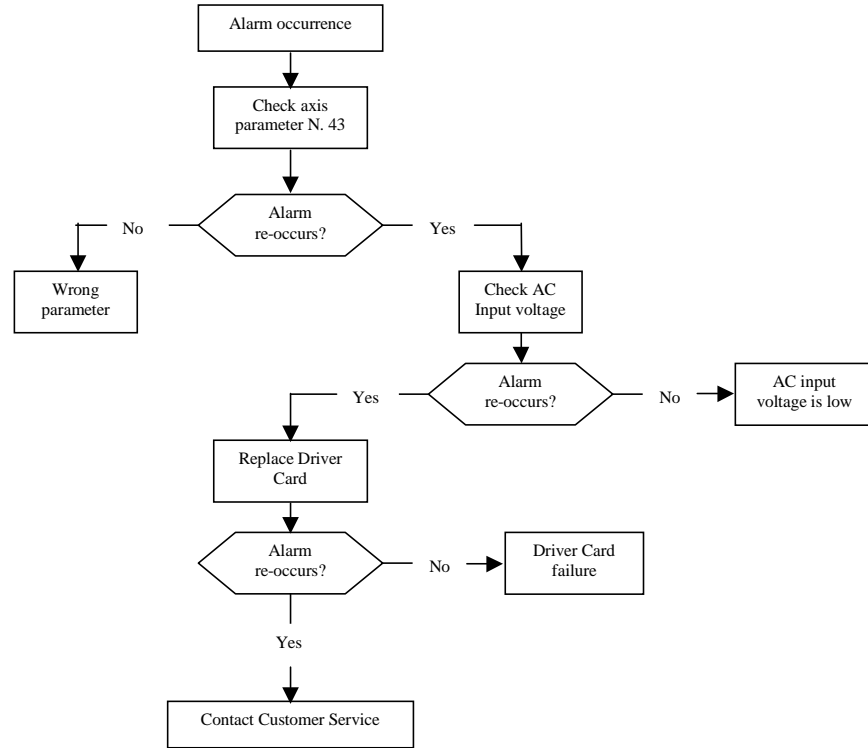

**Diagram 9**

**ERROR (271) ENCODER LOW BATTERY AXIS %**

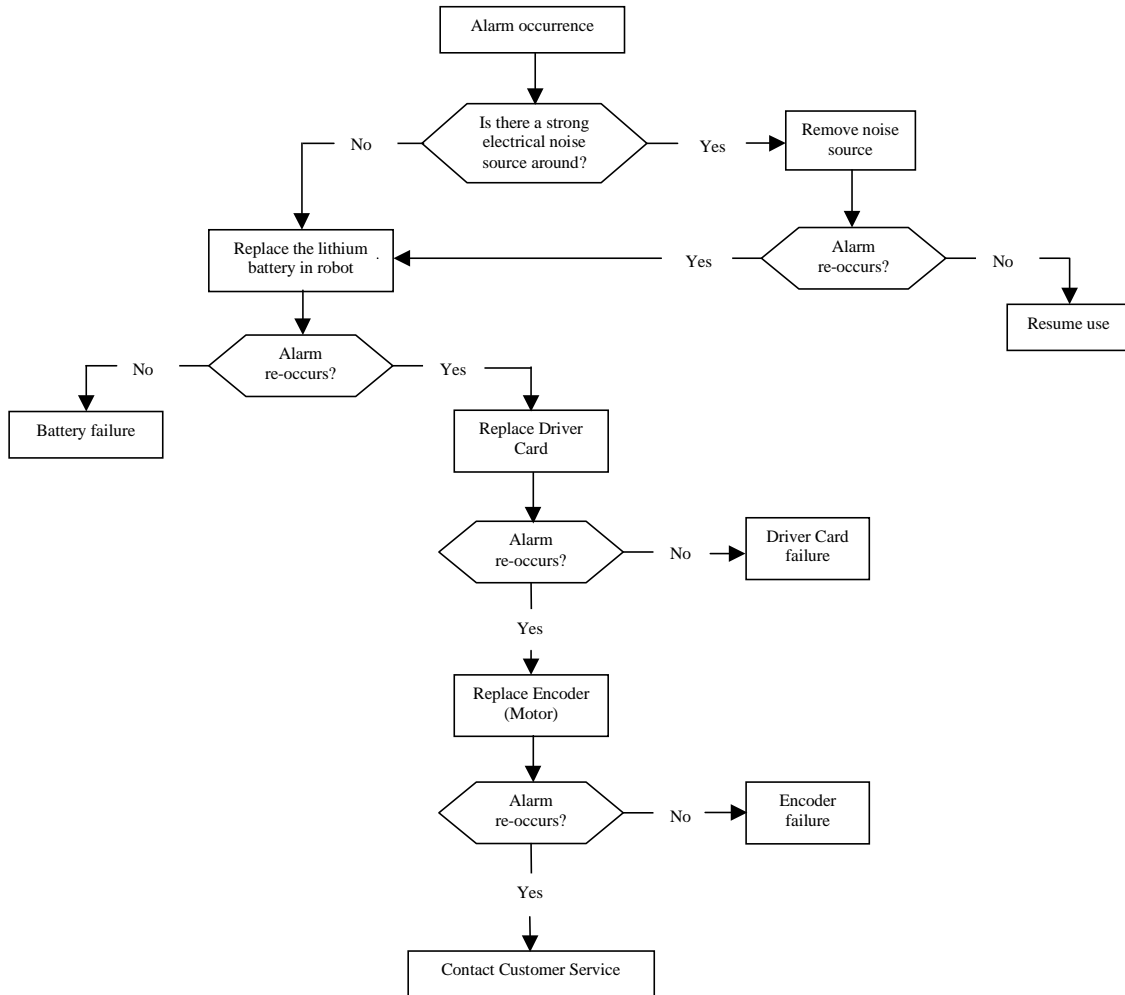

**Diagram 10**

**ERROR (308) DRIVER VOLTAGE FAILURE AXES % % %**

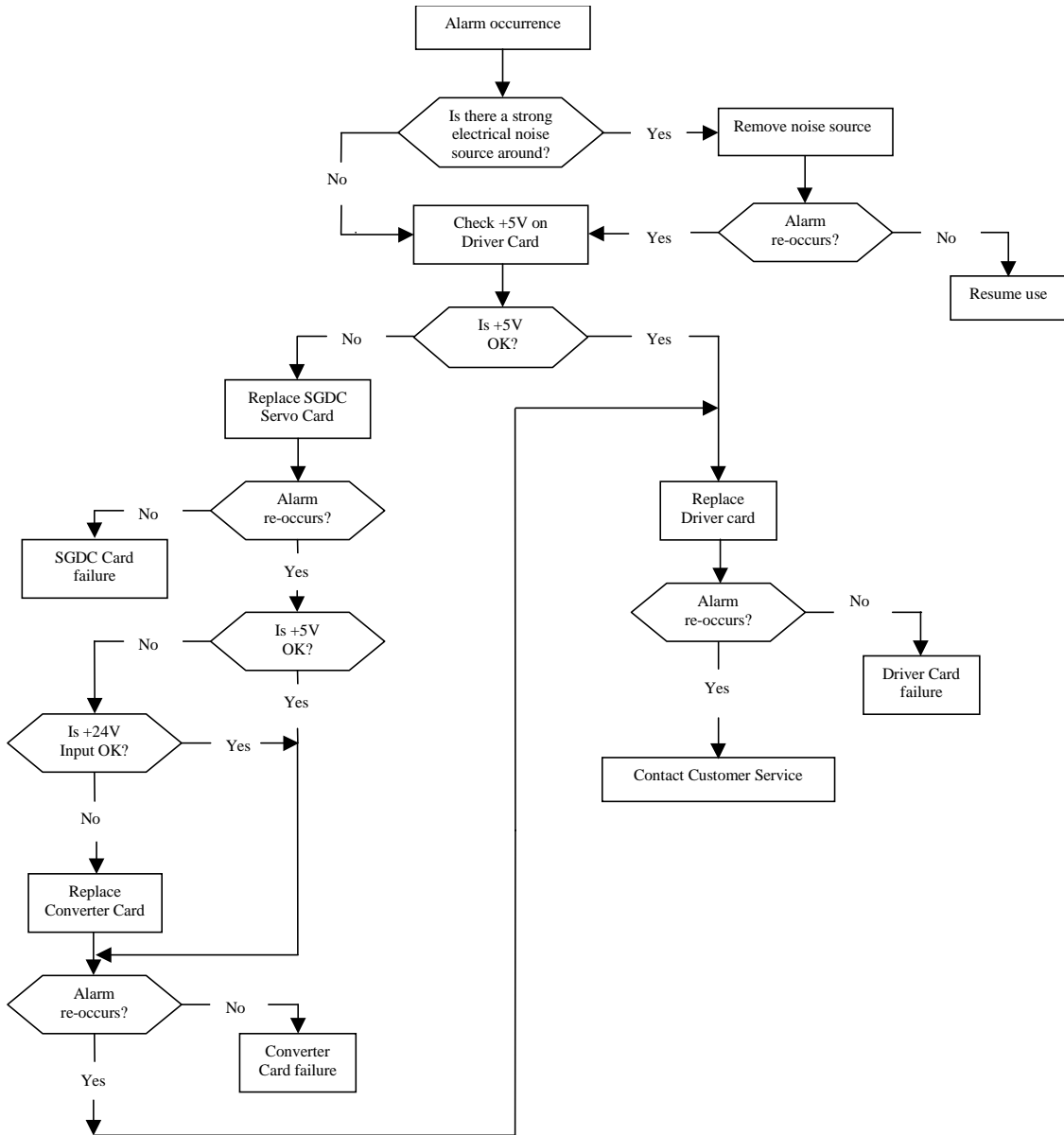

**Diagram 11**

**ERROR (324) COMMUNICATION ERROR WITH DRIVER**

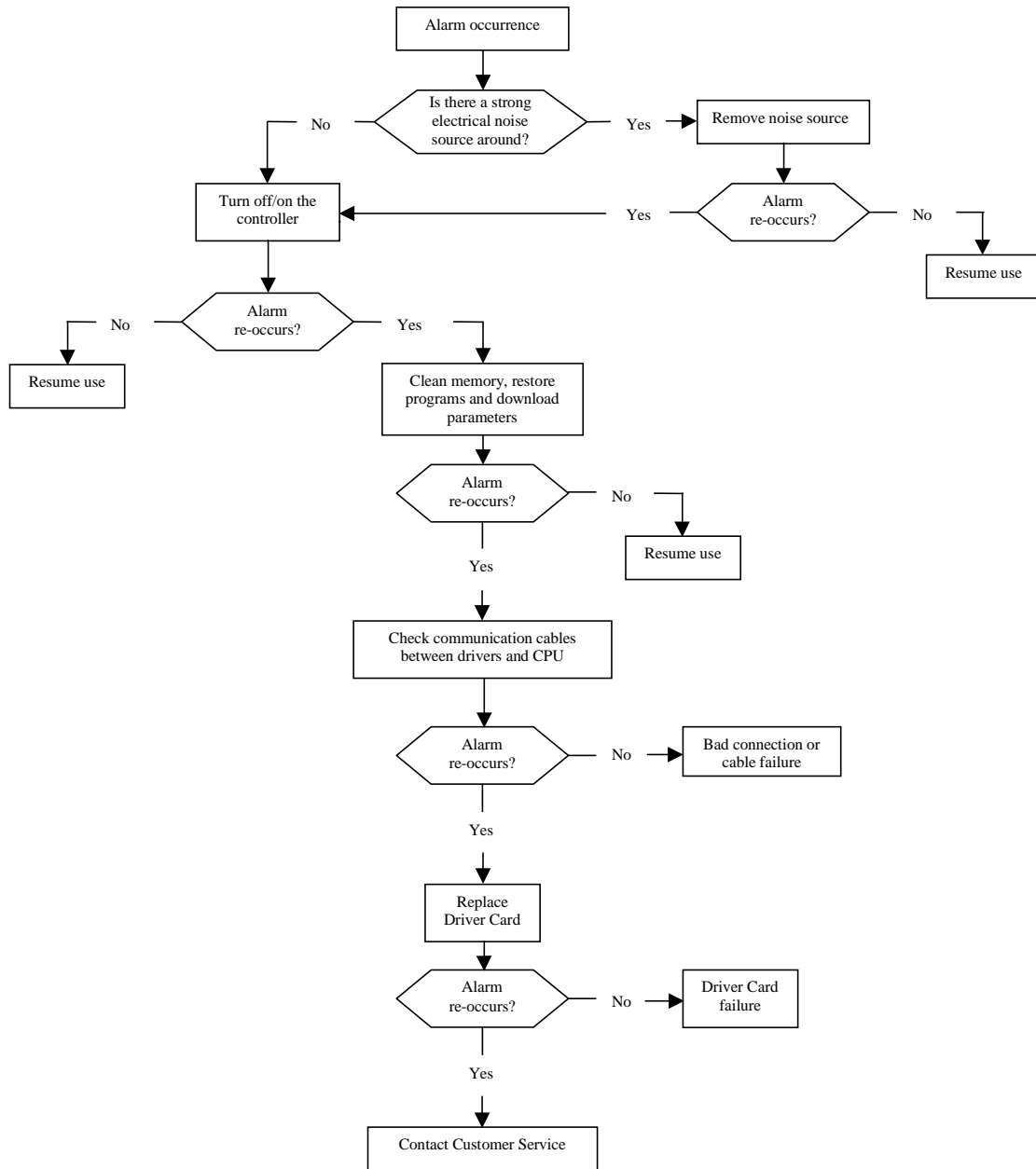

# 5

## Simplified Diagrams of BRC

### Main Power

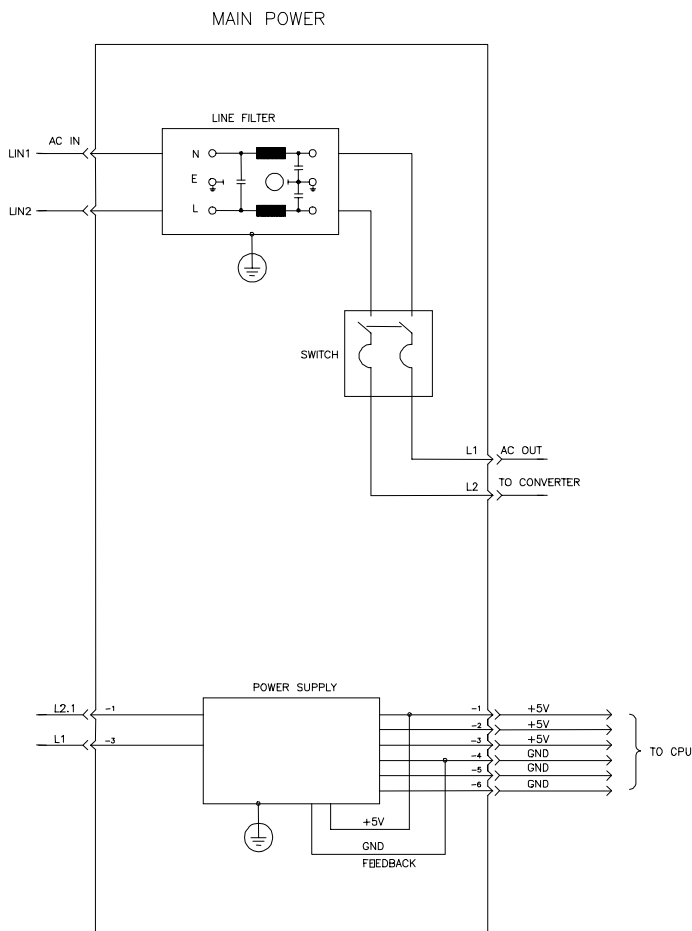

# CPU PC-37000

CPU PC-37000

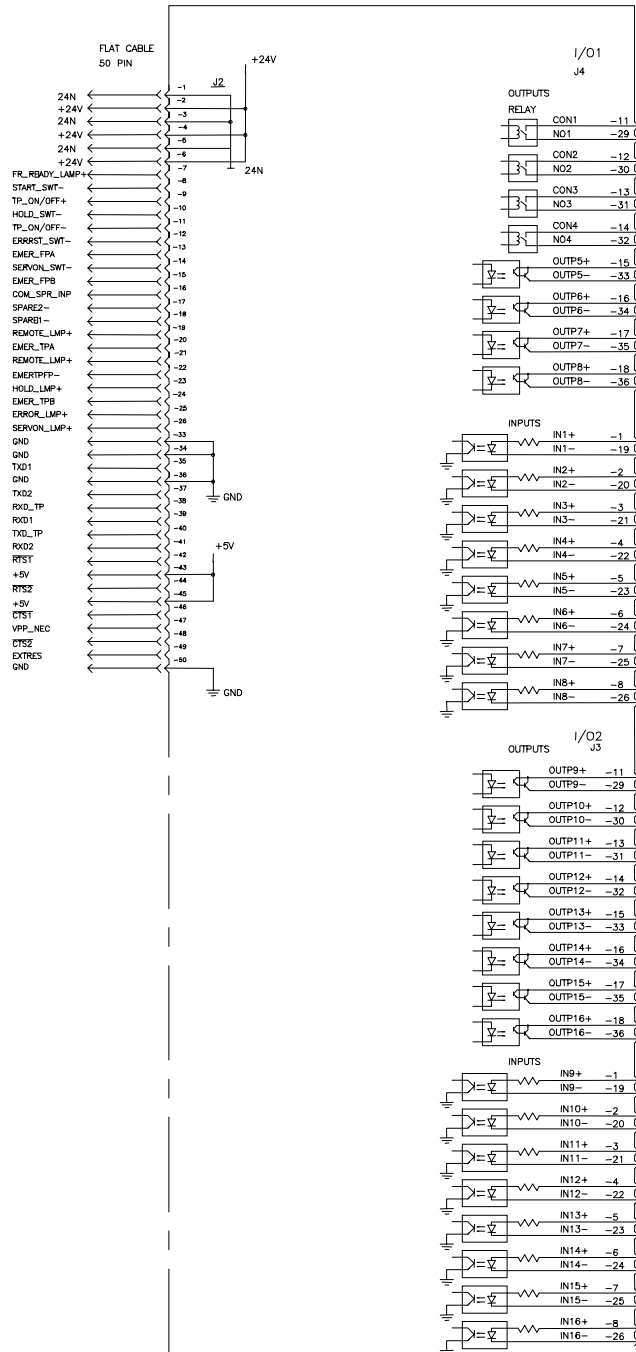



# CPU

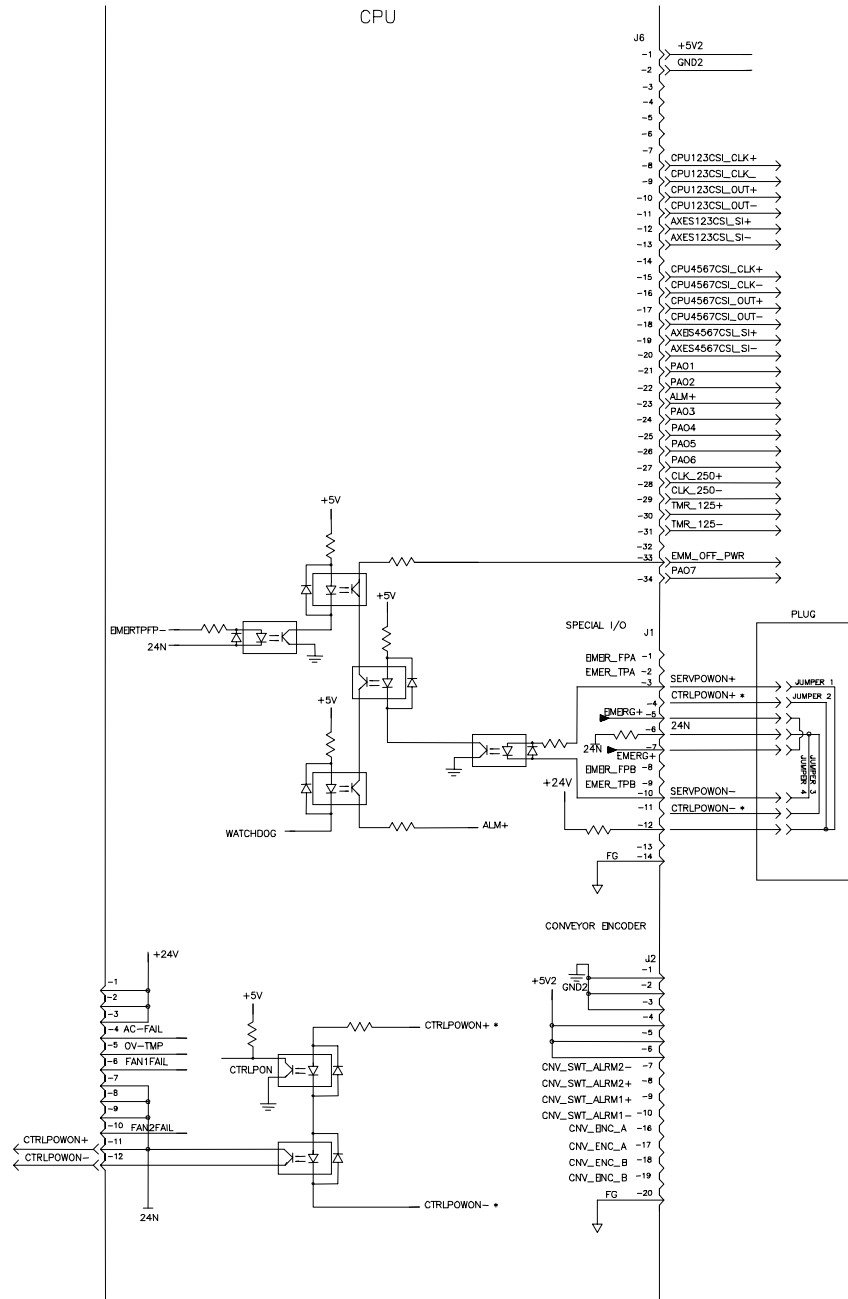

# Axis 1

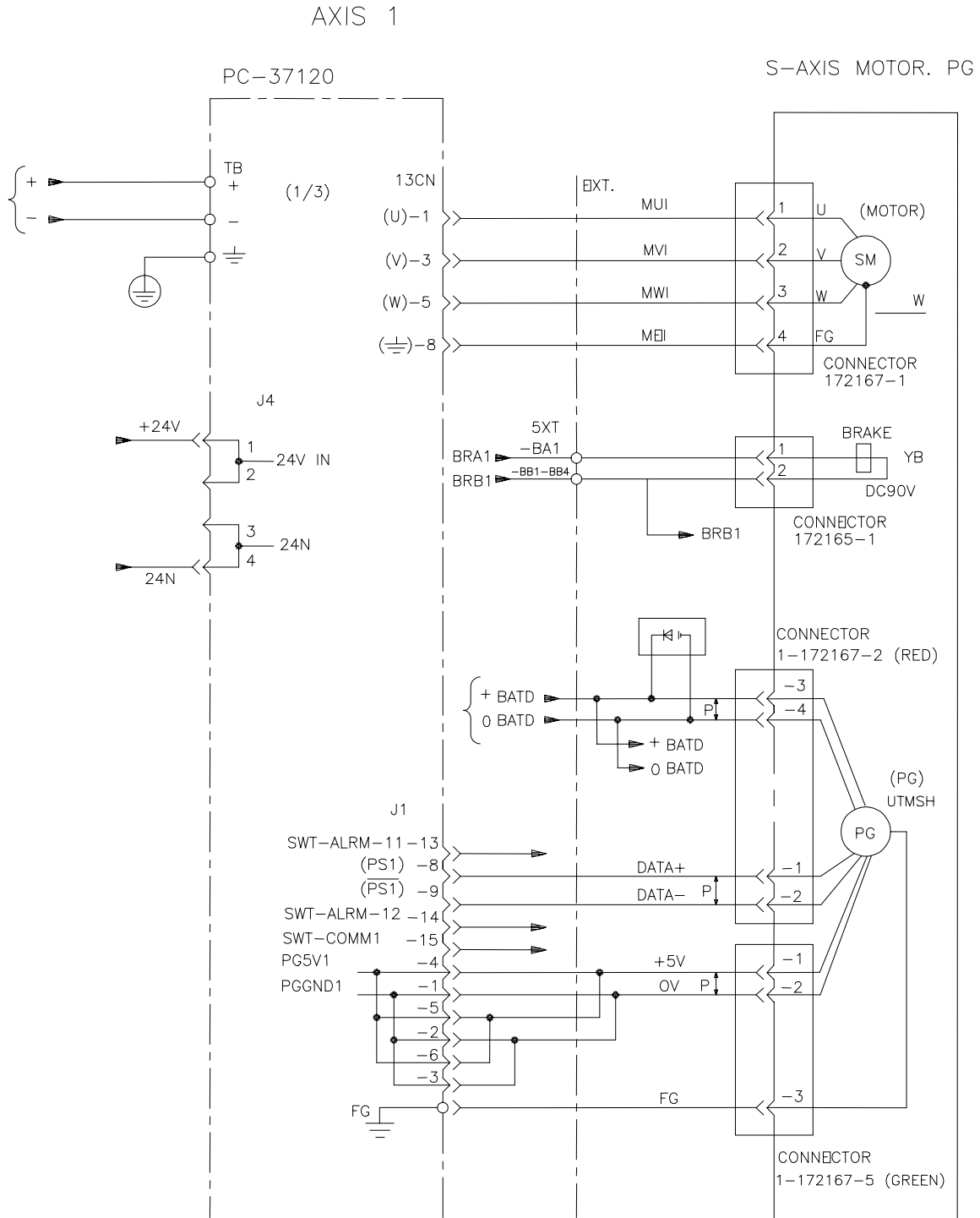

# Axis 2

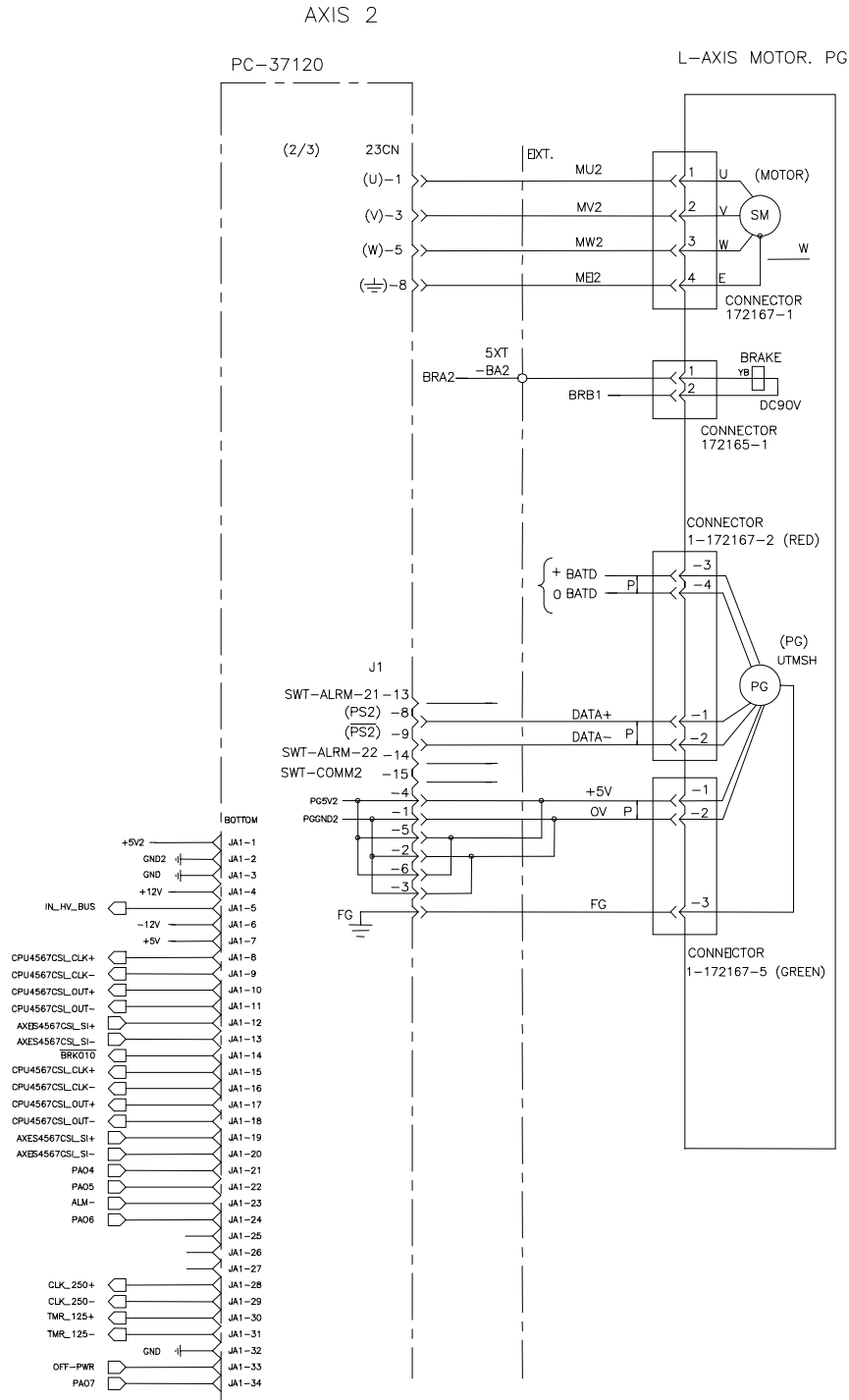

# Axis 3

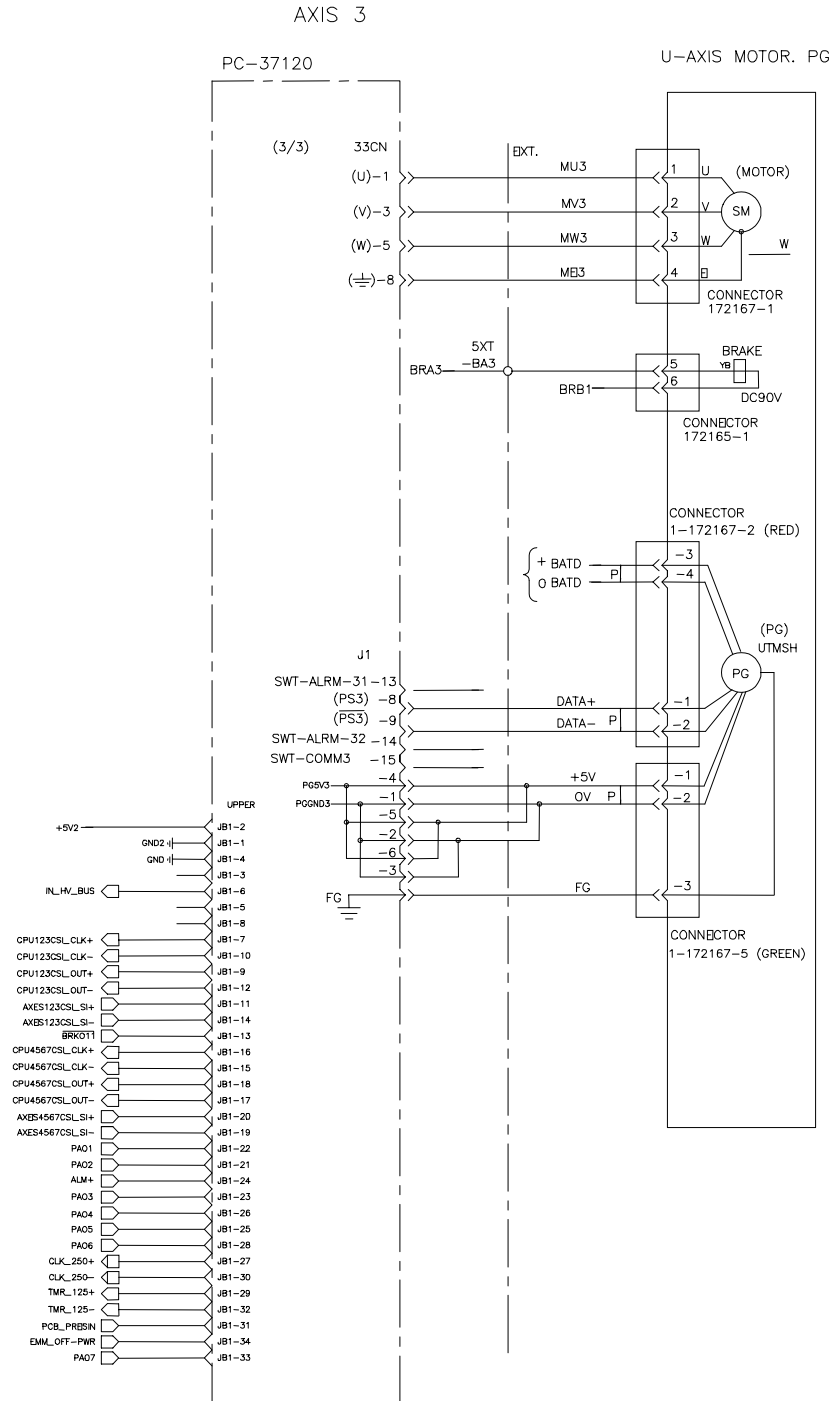

# Axis 4

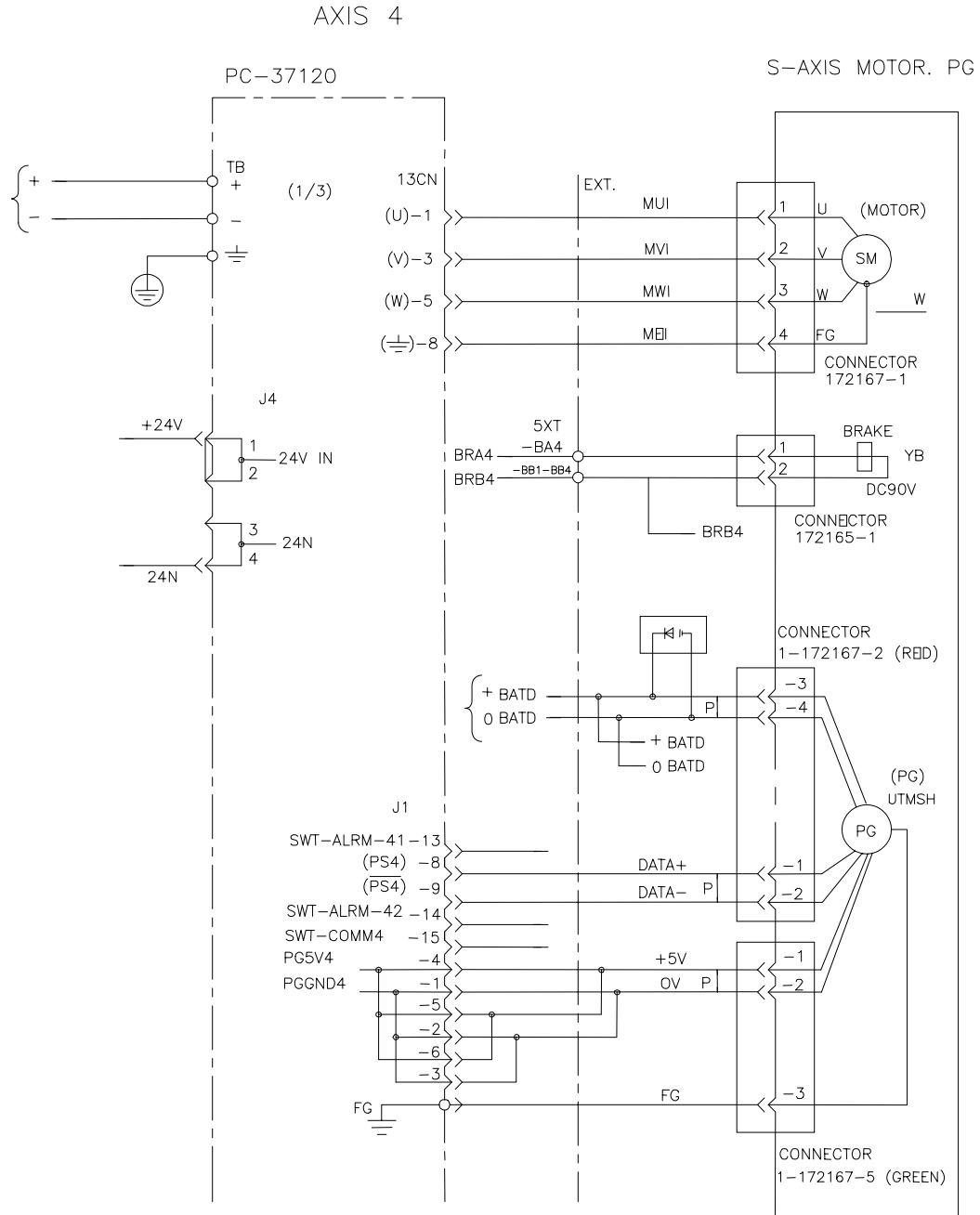

# Axis 5

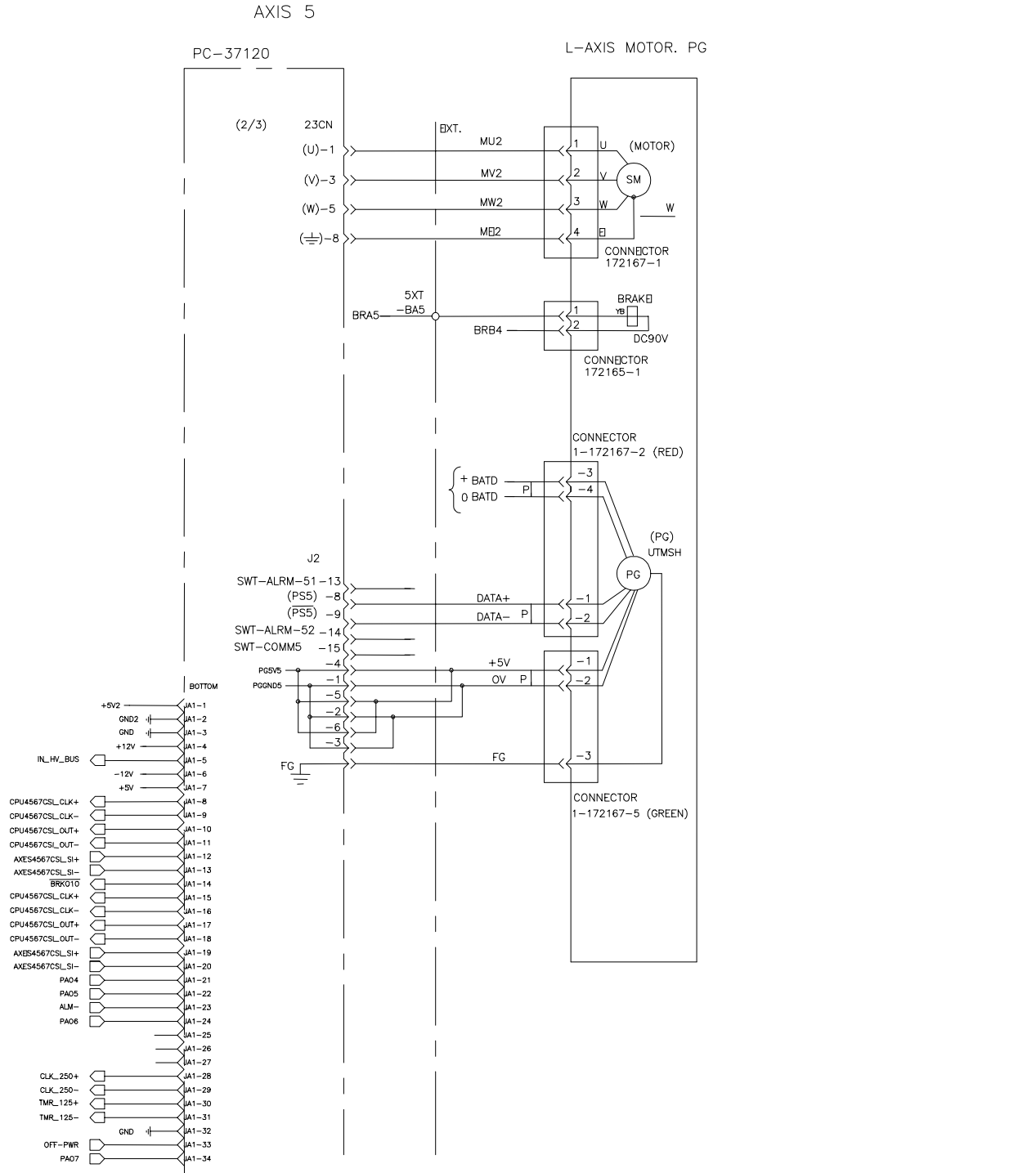

# Axis 6

AXIS 6

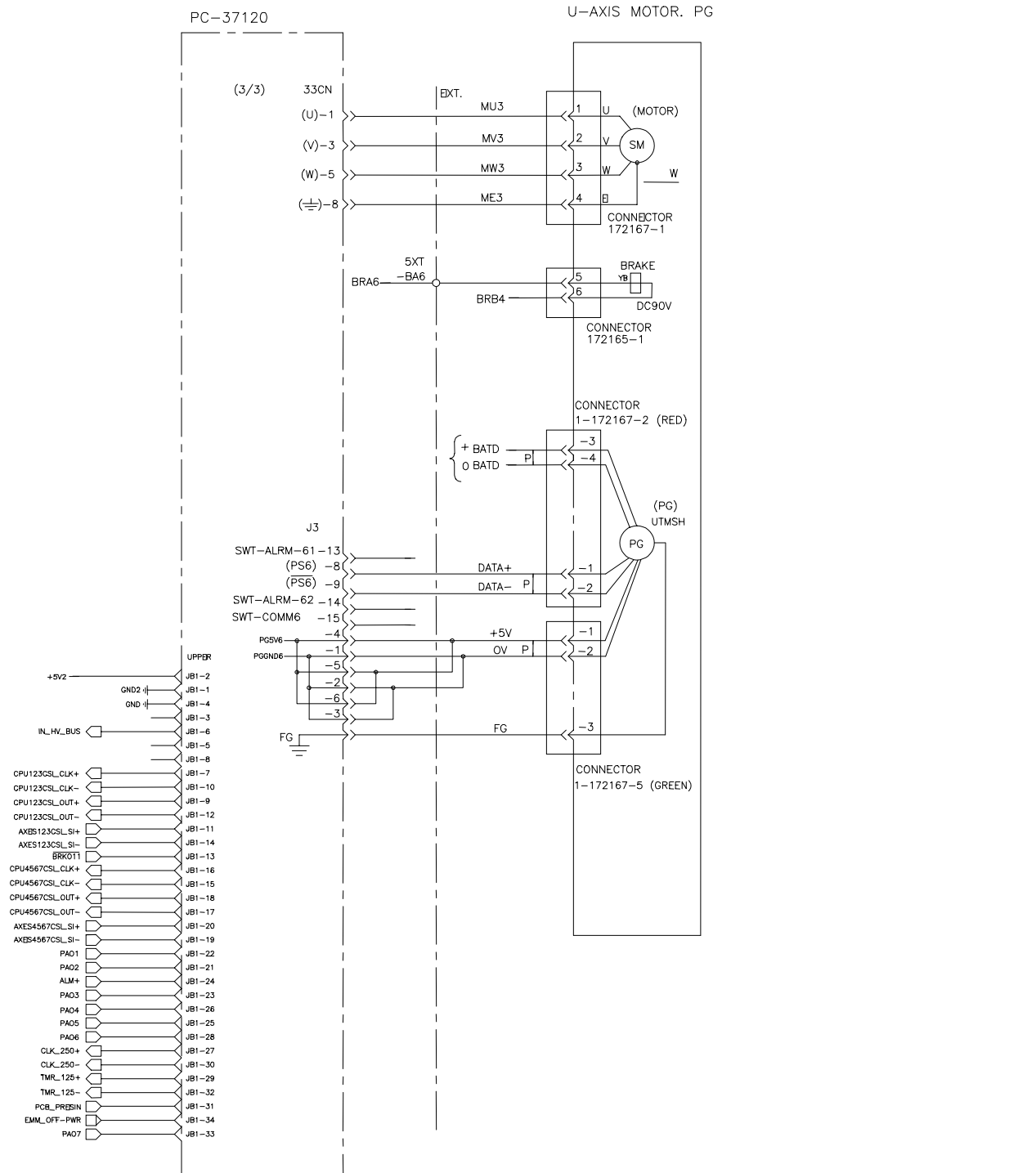

# Converter

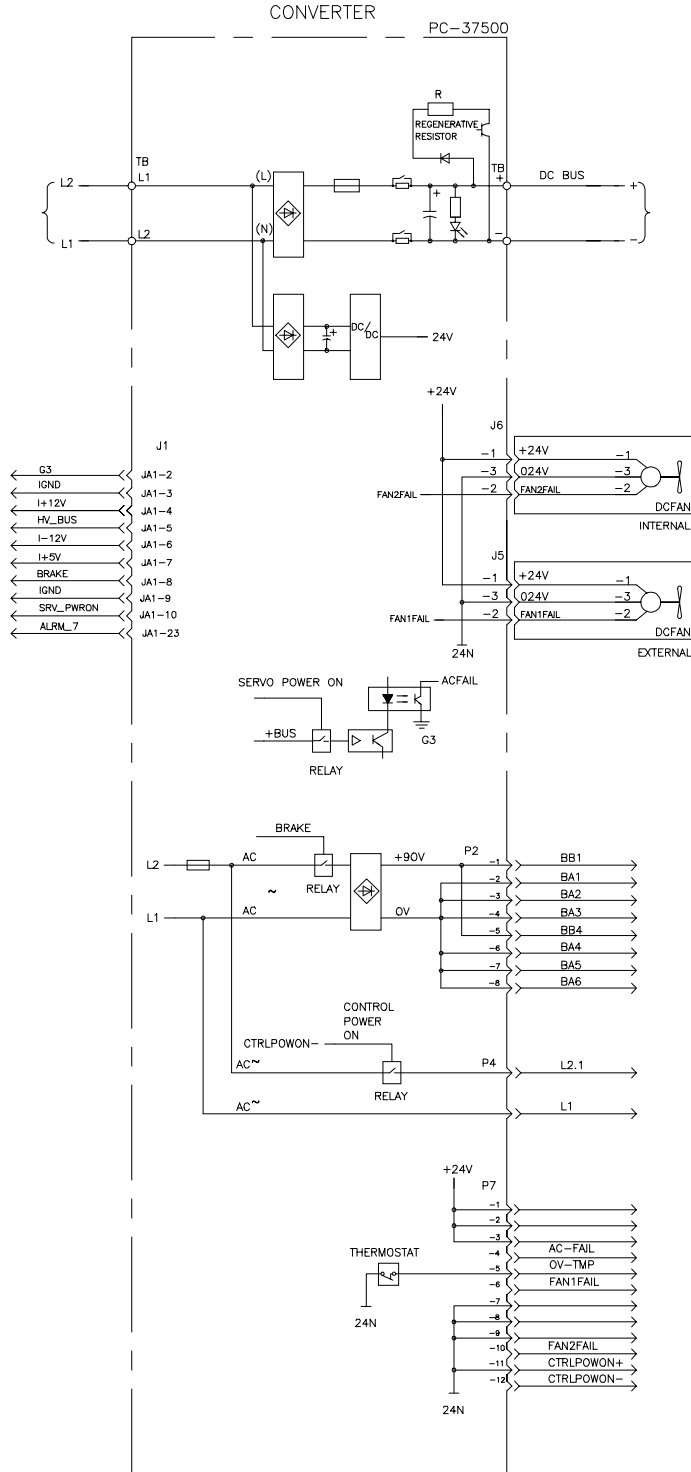



# Front Panel

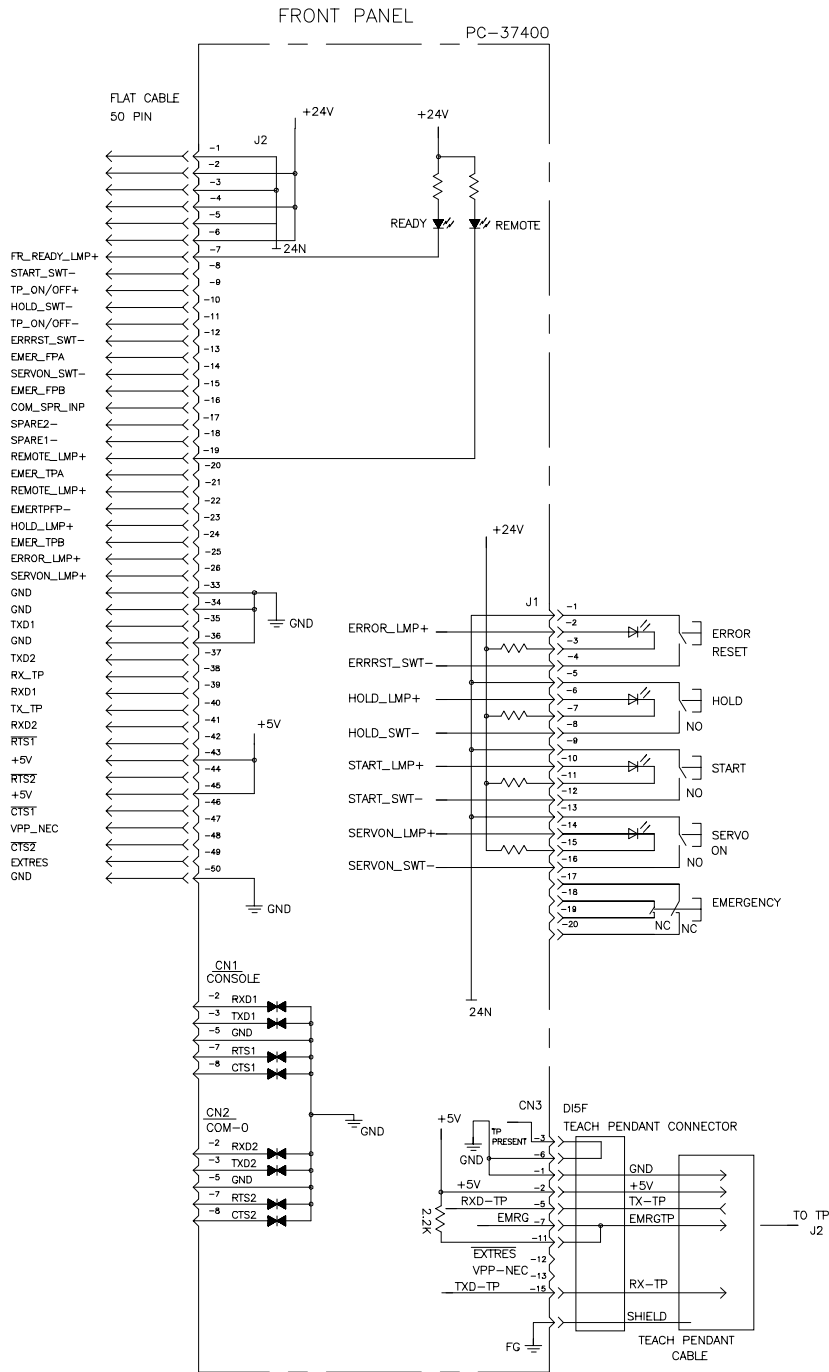

# Optional I/O PC-37600

I/O PC-37600

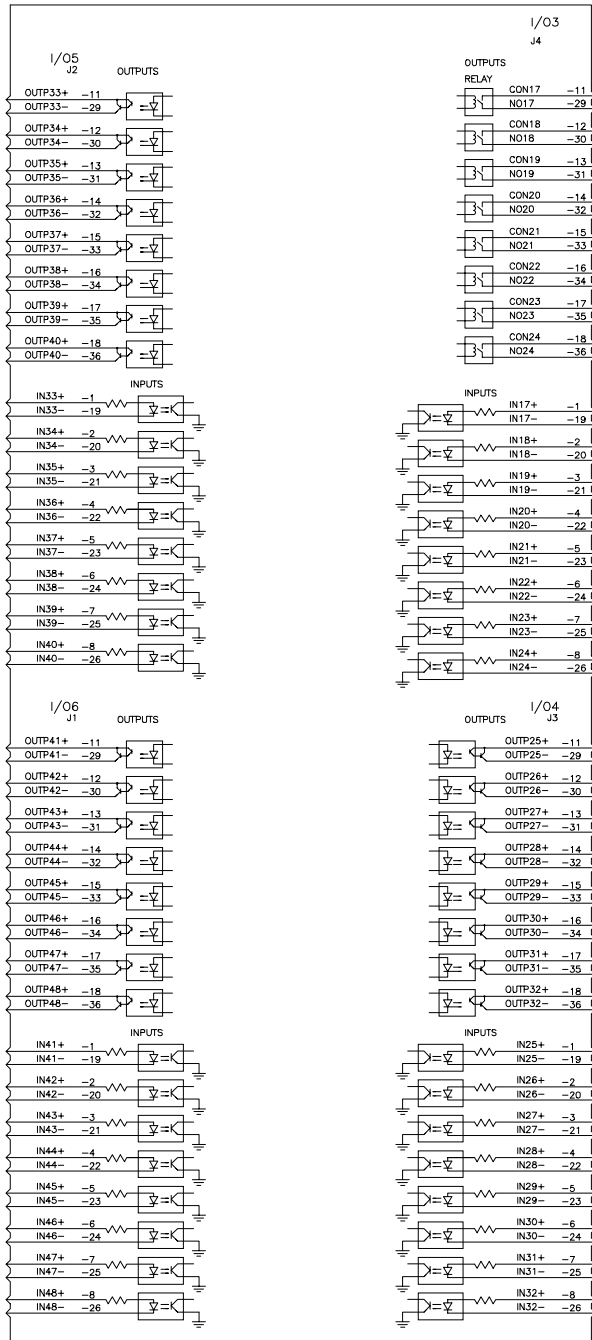

# 6

## Connectors

---

---

### I/O Connector - Block I

---

IN1+	1		19	IN1-
IN2+	2		20	IN2-
IN3+	3		21	IN3-
IN4+	4		22	IN4-
IN5+	5		23	IN5-
IN6+	6		24	IN6-
IN7+	7		25	IN7-
IN8+	8		26	IN8-
N.C.	9		27	N.C.
N.C.	10		28	N.C.
CON1	11		29	NO1
CON2	12		30	NO2
CON3	13		31	NO3
CON4	14		32	NO4
OUTP5+	15		33	OUTP5-
OUTP6+	16		34	OUTP6-
OUTP7+	17		35	OUTP7-
OUTP8+	18		36	OUTP8-

---

## I/O Connector - Block II

IN9+	1		19	IN9-
IN10+	2		20	IN10-
IN11+	3		21	IN11-
IN12+	4		22	IN12-
IN13+	5		23	IN13-
IN14+	6		24	IN14-
IN15+	7		25	IN15-
IN16+	8		26	IN16-
N.C.	9		27	N.C.
N.C.	10		28	N.C.
OUTP9+	11		29	OUTP9-
OUTP10+	12		30	OUTP10-
OUTP11+	13		31	OUTP11-
OUTP12+	14		32	OUTP12-
OUTP13+	15		33	OUTP13-
OUTP14+	16		34	OUTP14-
OUTP15+	17		35	OUTP15-
OUTP16+	18		36	OUTP16-

---

## Optional I/O Card Connectors - Block III

IN17+	1		19	IN17-
IN18+	2		20	IN18-
IN19+	3		21	IN19-
IN20+	4		22	IN20-
IN21+	5		23	IN21-
IN22+	6		24	IN22-
IN23+	7		25	IN23-
IN24+	8		26	IN24-
N.C.	9		27	N.C.
N.C.	10		28	N.C.
CON17	11		29	NO17
CON18	12		30	NO18
CON19	13		31	NO19
CON20	14		32	NO20
CON21	15		33	NO21
CON22	16		34	NO22
CON23	17		35	NO23
CON24	18		36	NO24

---

## Optional I/O Card Connectors - Block IV

IN25+	1		19	IN25-
IN26+	2		20	IN26-
IN27+	3		21	IN27-
IN28+	4		22	IN28-
IN29+	5		23	IN29-
IN30+	6		24	IN30-
IN31+	7		25	IN31-
IN32+	8		26	IN32-
N.C.	9		27	N.C.
N.C.	10		28	N.C.
OUTP25-	11		29	OUTP25+
OUTP26-	12		30	OUTP26+
OUTP27-	13		31	OUTP27+
OUTP28-	14		32	OUTP28+
OUTP29-	15		33	OUTP29+
OUTP30-	16		34	OUTP30+
OUTP31-	17		35	OUTP31+
OUTP32-	18		36	OUTP32+

---

## Optional I/O Card Connectors - Block V

IN33+	1		19	IN33-
IN34+	2		20	IN34-
IN35+	3		21	IN35-
IN36+	4		22	IN36-
IN37+	5		23	IN37-
IN38+	6		24	IN38-
IN39+	7		25	IN39-
IN40+	8		26	IN40-
N.C.	9		27	N.C.
N.C.	10		28	N.C.
OUTP33-	11		29	OUTP33+
OUTP34-	12		30	OUTP34+
OUTP35-	13		31	OUTP35+
OUTP36-	14		32	OUTP36+
OUTP37-	15		33	OUTP37+
OUTP38-	16		34	OUTP38+
OUTP39-	17		35	OUTP39+
OUTP40-	18		36	OUTP40+

---

## Optional I/O Card Connectors - Block VI

IN41+	1		19	IN41-
IN42+	2		20	IN42-
IN43+	3		21	IN43-
IN44+	4		22	IN44-
IN45+	5		23	IN45-
IN46+	6		24	IN46-
IN47+	7		25	IN47-
IN48+	8		26	IN48-
N.C.	9		27	N.C.
N.C.	10		28	N.C.
OUTP41-	11		29	OUTP41+
OUTP42-	12		30	OUTP42+
OUTP43-	13		31	OUTP43+
OUTP44-	14		32	OUTP44+
OUTP45-	15		33	OUTP45+
OUTP46-	16		34	OUTP46+
OUTP47-	17		35	OUTP47+
OUTP48-	18		36	OUTP48+



---

## RS-232 Connectors

### Console Connector

N.C.	1
RXD1	2
TXD1	3
N.C.	4
GND	5
N.C.	6
$\overline{\text{RTS1}}$	7
$\overline{\text{CTS1}}$	8
N.C.	9

### COM-0 Connector

N.C.	1
RXD2	2
TXD2	3
N.C.	4
GND	5
N.C.	6
$\overline{\text{RTS2}}$	7
$\overline{\text{CTS2}}$	8
N.C.	9

## Special I/O Connector

EMER_FPA	1		8	EMER_FPB
EMER_TPA	2		9	EMER_TPB
SERVPOWON+	3		10	SERVPOWON-
CTRLPOWON-	4		11	CTRLPOWON-
EMRG+	5		12	+V_SP_10
-V_SP_10	6		13	N.C.
EMRG-	7		14	FG

## Special I/O Plug Interconnections

(connected to special I/O connector)

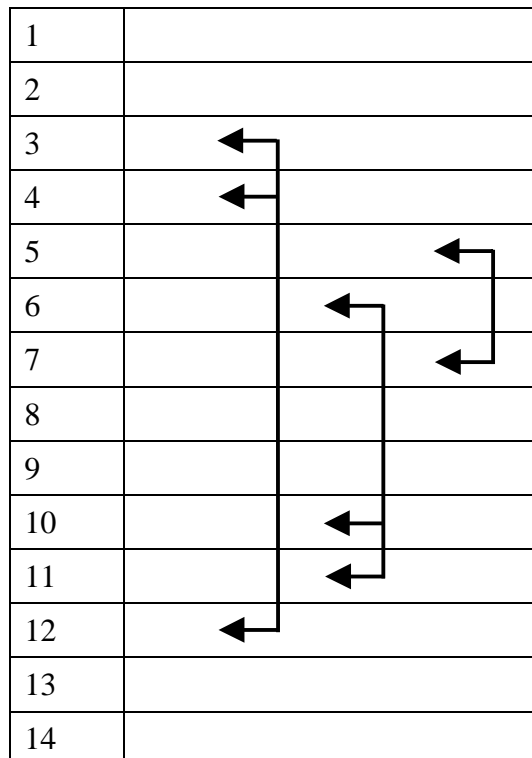

---

## Conveyor Encoder Connector

GND2	1		11	N.C
GND2	2		12	N.C.
GND2	3		13	N.C.
5PG	4		14	N.C
5PG	5		15	N.C.
5PG	6		16	CNV_ENC_A
CNV_SWT_ALARM2-	7		17	CNV_ENC_A $\bar{A}$
CNV_SWT_ALARM2+	8		18	CNV_ENC_B
CNV_SWT_ALARM1+	9		19	CNV_ENC_B $\bar{B}$
CNV_SWT_ALARM1-	10		20	FG

# 7

## Interface Circuits

This section shows examples of I/O signal connections.

### Sequence Input Circuit Interface

The sequence input circuit interface connects through a relay or open-collector transistor circuit. Select a low-current relay otherwise a faulty contact will result.

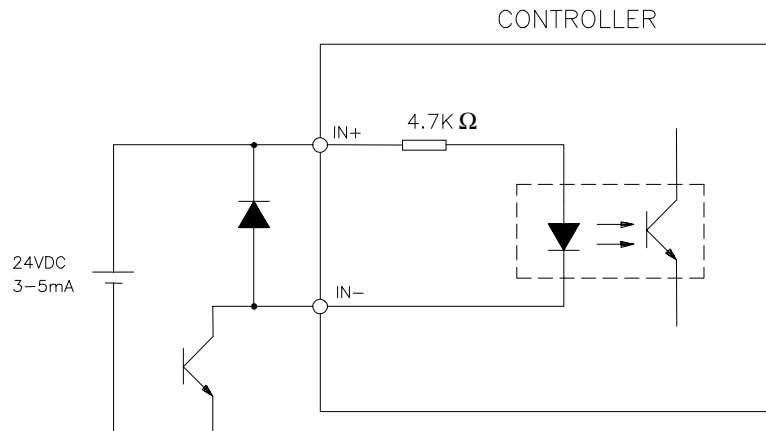
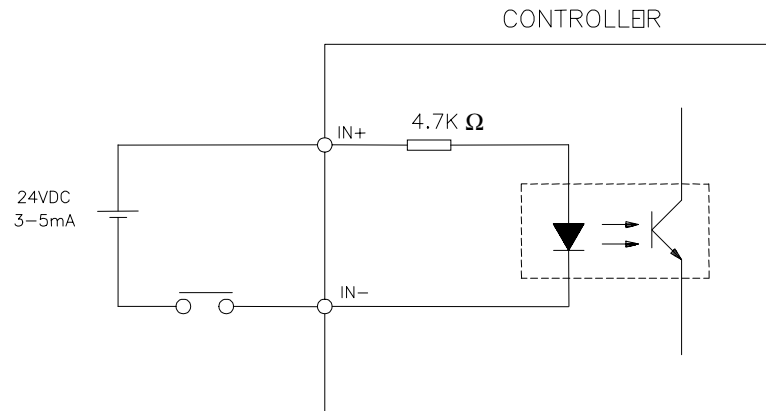

---

## Output Circuit Interfaces

The Controller has two types of output circuits:

- Relay type
- Open-collector transistor type

Outputs numbers 1 through 4 are relay type.

Outputs numbers 5 through 16 are transistor type.

### Relay type output

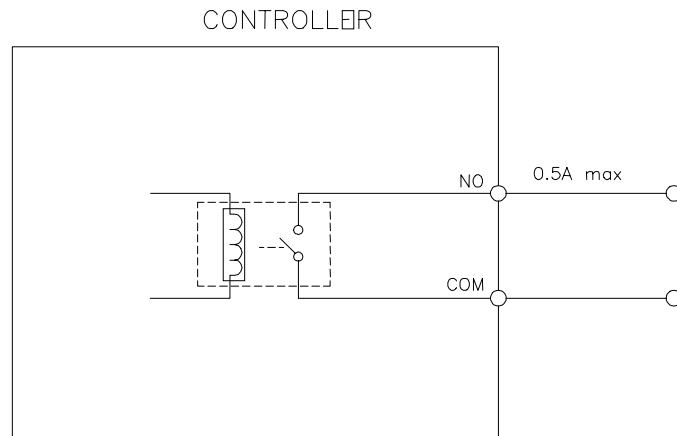

## Open-collector transistor type output

Connect an open-collector output circuit through a photocoupler, relay or line receiver circuit.

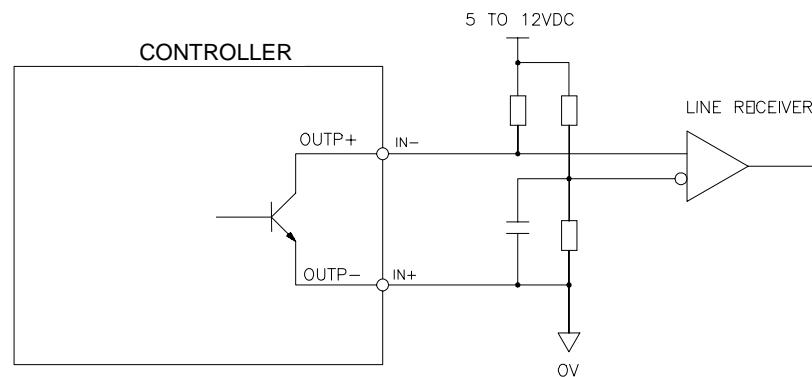
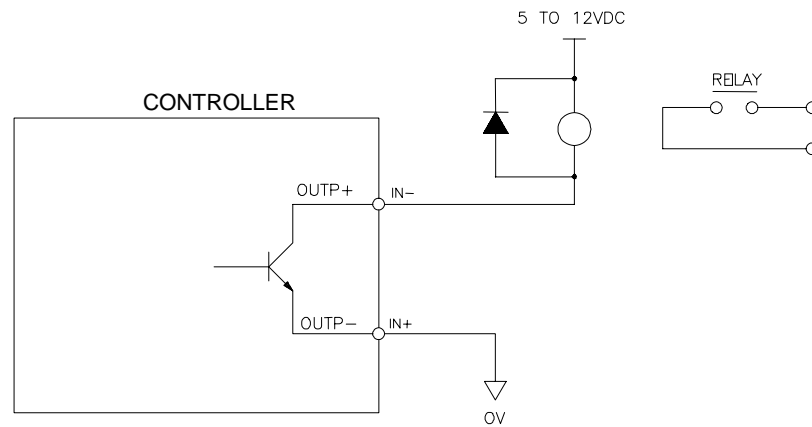
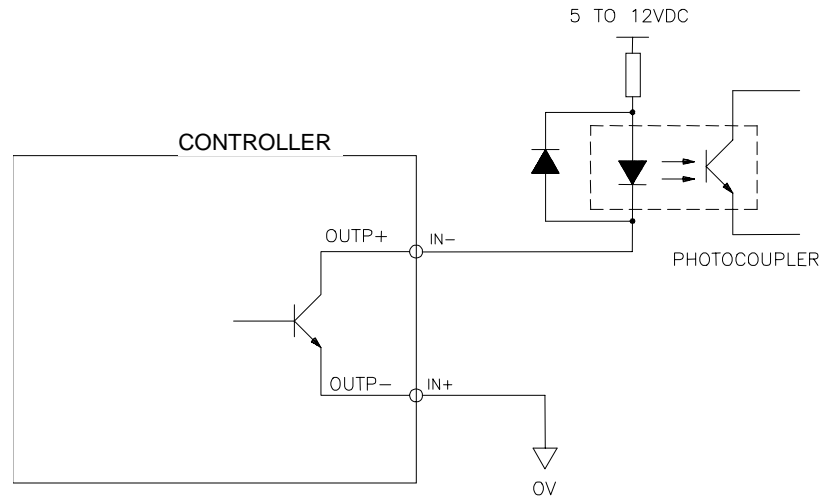

Note: The maximum allowable voltage and current capacities for open-collector output circuits are as follows:

- Voltage: 30VDC max
- Current: 20mA DC

---

## Spare Parts List

Description	Quantity
Emergency stop pushbutton	1
Pushbutton white lens	3
Pushbutton green lens	1
Front panel interface card	1
Internal fan assembly	1
External fan assembly	1
Power supply 5V, 11A LPQ-42	1
On/off rocker switch	1
Control card	2
CPU card	1
Converter card	1
AC power cable 250V 16A	1
Teach pendant	1
Battery	1